

Schwenkbereich $\pm 105^\circ$
Swivel area $\pm 105^\circ$

Spannzange / Collet ER16 DIN6499
Spannbereich / Clamping range: 1,0 - 10,0

Gewindebohrzange / Tapping Collet
ET-1-16 M1-M6

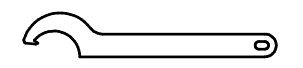
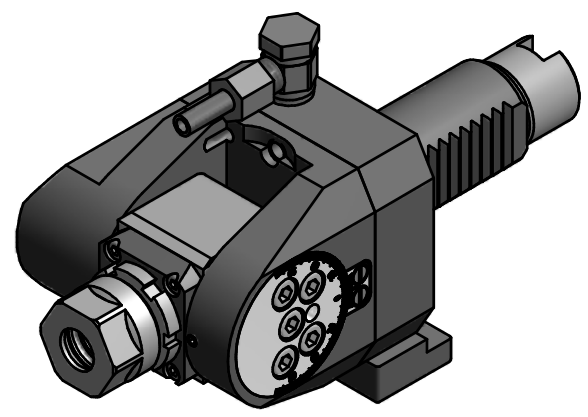

Hakenschlüssel
mit Nase
Hook wrench with
nose end
DIN1810 A 30x32

Copyright **EWS Tool Technologies**
Weitergabe und Vervielfaeltigung dieser Unterlage,
Verwertung und Mitteilung ihres Inhalts nicht
gestattet, soweit nicht ausdrecklich zugestanden.
Zuwiderhandlungen verpflichten zu Schadenersatz.

Bemerkung - Note	Technische Daten - technical data M1 / M2 = 16 / 8 Nm n1 / n2 = 6000 / 12000 1/min i (N1:N2) = 1:2	Benennung - Title Schwenkkopf <i>Swivel head</i>	name	date	Technische Aenderungen vorbehalten! Subject to technical modifications!	
			drawing	Theiss		
			Weigele GmbH & Co. KG Maybachstr. 1 D-73066 UHINGEN Tel. +49(0)7161/93040-10		Nr. 63.3016G3001V	DIN A3
			File: D-EWS-187761-idw		Blatt - page 1 (1)	