

Spannzange / collet ER20 DIN6499
 Spannungsbereich / clamping range: 1,0 - 13,0

Gewindebohrzange / tapping collet
 ET-1-20 M2-M6

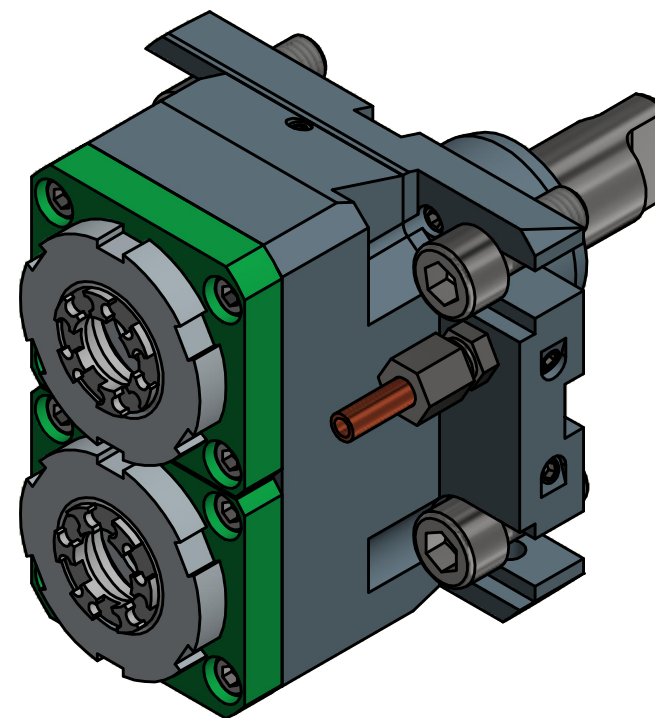

Hakenschlüssel
 mit Nase
*Hook wrench with
 nose end*
 DIN1810 A 45x50

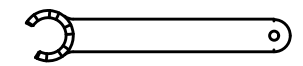

Spannzangenschlüssel für
 innenliegende Mutter
*Clamping wrench for
 internal collet*
 220AX

Copyright **EWS Tool Technologies**
 Weitergabe und Vervielfältigung dieser Unterlage,
 Verwertung und Mitteilung ihres Inhalts nicht
 gestattet, soweit nicht ausdrücklich zugestanden.
 Zuwiderhandlungen verpflichten zu Schadenersatz.

Bemerkung - Note

Technische Daten - technical data

Benennung - Title

Weight = 3.430 [kg]
 Torque max. (M1/M2) = 25 / 12,5 | 12,5 [Nm]
 Speed max. (n1/n2) = 6000 / 6000 | 6000 [1/min]
 Gear ratio (i)=n1:n2 = 1:1 | 1:1

Axial Bohr und Fräskopf
Axial drilling and milling head



Nr. - No.
40.4020DYNZTK50IM

Technische Änderungen vorbehalten!
 Subject to technical modifications!
 IDENT: DEWS119682

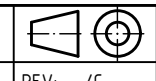

REV: -/C

MNR.
141133

