

Kühlmittelezufuhr  
coolant supply

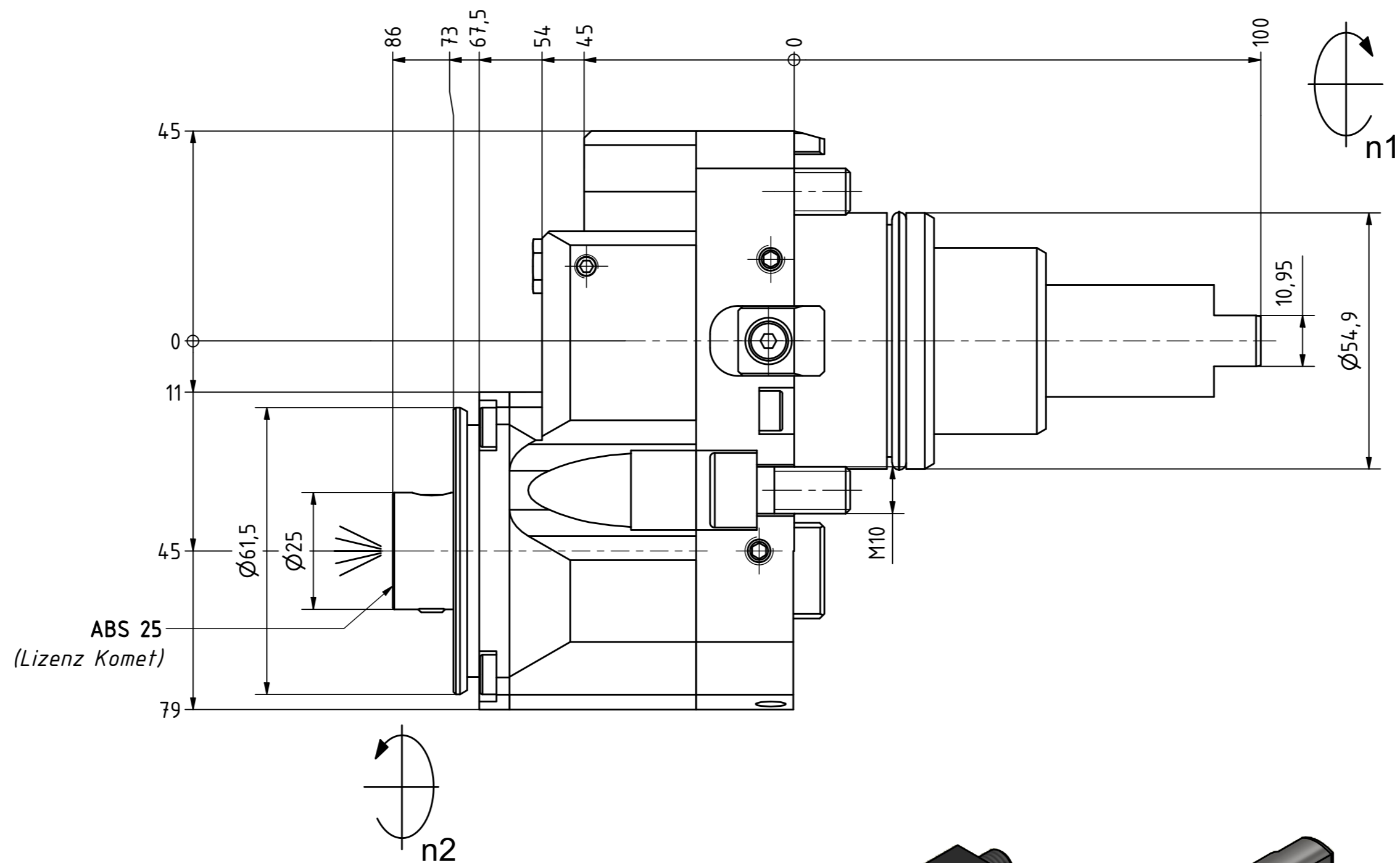

ABS 25  
(Lizenz Komet)

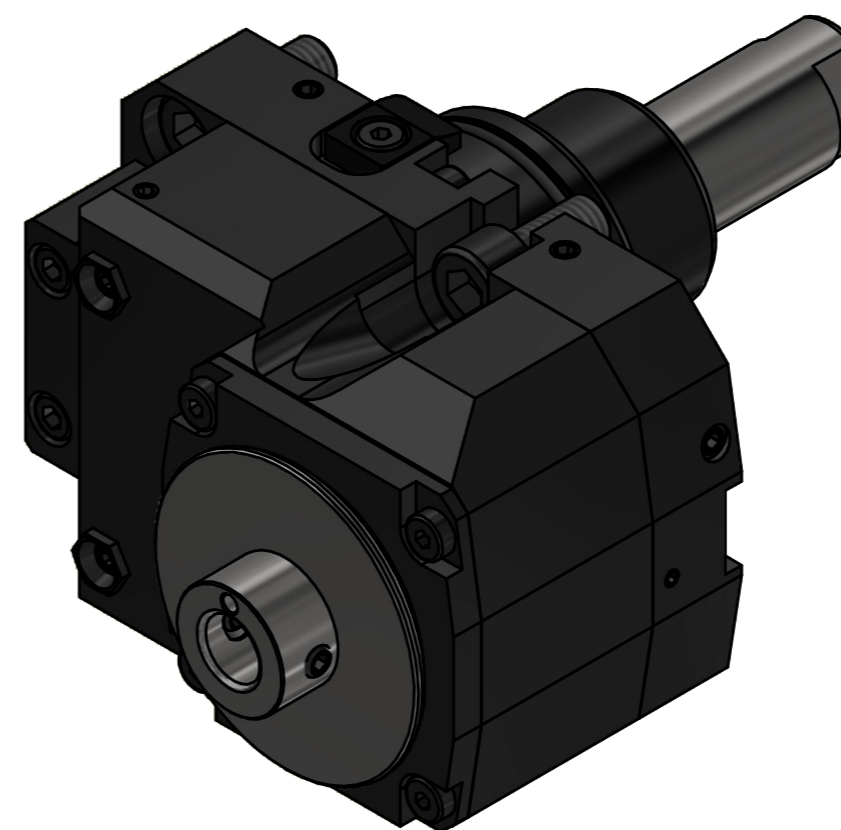
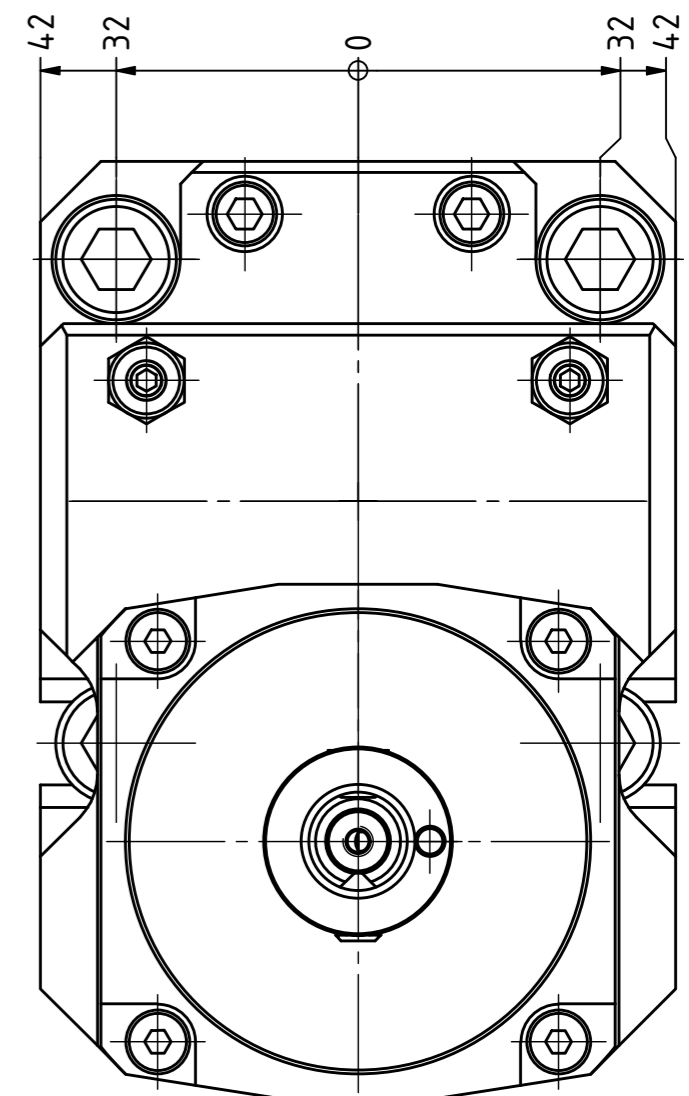

MMS - max. 10 bar  
MQL - max. 10 bar

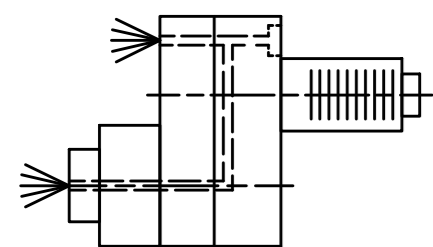

Innen- und Aussenkuehlung / Inside and outside coolant supply  
Kuehlmittefiltrierung<math>50\mu</math> / coolant filtration<math>50\mu</math>

Copyright **EWS Tool Technologies**  
Weitergabe und Vervielfaeltigung dieser Unterlage,  
Verwertung und Mitteilung ihres Inhalts nicht  
gestattet, soweit nicht ausdrecklich zugestanden.  
Zuwiderhandlungen verpflichten zu Schadenersatz.

<p>Bemerkung - Note Für Trockenlauf geeignet! Use without coolant fluid allowed!</p>	<p>Technische Daten - technical data Weight = 4,758 [kg] Torque max. (M1/M2) = 48 / 16 [Nm] Speed max. (n1/n2) = 6000 / 18000 [1/min] Gear ratio (i)=n1:n2 = 1:3 Pressure (pmax) = 10 [bar]</p>	<p>Benennung - Title <b>Axial Bohr u. Fräskopf achsversetzt</b> <b>Ax. drill. and mill. head offset</b></p>	<p><b>EWS</b> Tool Technologies EWS Weigle GmbH &amp; Co. KG Maybachstr. 1 D-73066 Uhlingen www.ews-tool.de</p>	<p>Technische Aenderungen vorbehalten! Subject to technical modifications! IDENT: DEWS14.7669 REV: -/C</p>	<p>MNR. 209484 <b>QR</b></p>
--	---	---	---	--	--------------------------------------