

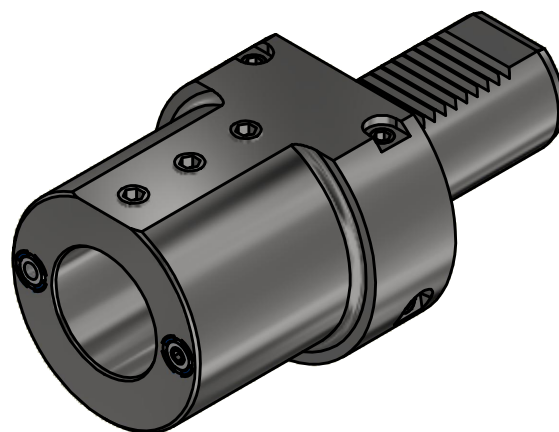

Achtung: Darf nur mit Verschlussstopfen verwendet werden!  
 Attention: May only be used with sealing plug!

Anzugsmoment: 40 Nm  
 Tightening torque: 40 Nm



Copyright **EWS Tool Technologies**  
 Weitergabe und Vervielfältigung dieser Unterlage,  
 Verwertung und Mitteilung ihres Inhalts nicht  
 gestattet, soweit nicht ausdrücklich zugestanden.  
 Zuwiderhandlungen verpflichten zu Schadenersatz.

Bemerkung - Note	Technische Daten - technical data Weight = 2.650 [kg]	Benennung - Title <b>Bohrstangenhalter</b> <i>Boring bar holder</i>	<b>EWS</b> Tool Technologies <small>EWS Weigle GmbH &amp; Co. KG          Maybachstr. 1          D-73066 Uhingen          www.ews-tools.de</small>	Technische Änderungen vorbehalten! Subject to technical modifications! IDENT: D-EWS-198101	 REV: -/A MNR. <b>137405</b>	
		Nr. - No. <b>19.4038.1</b>				