

Spannzange / collet ER32 DIN6499
Spannbereich / clamping range: 2,0 - 20,0

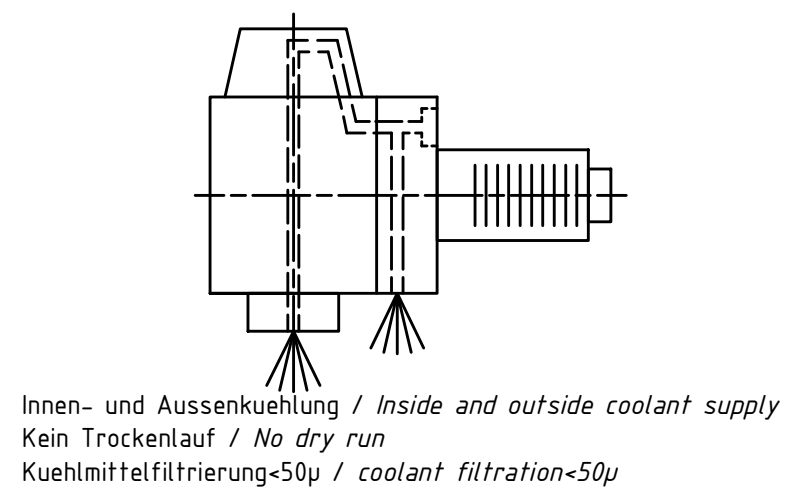
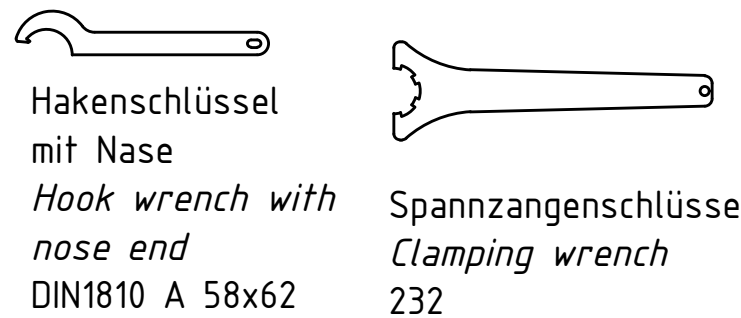
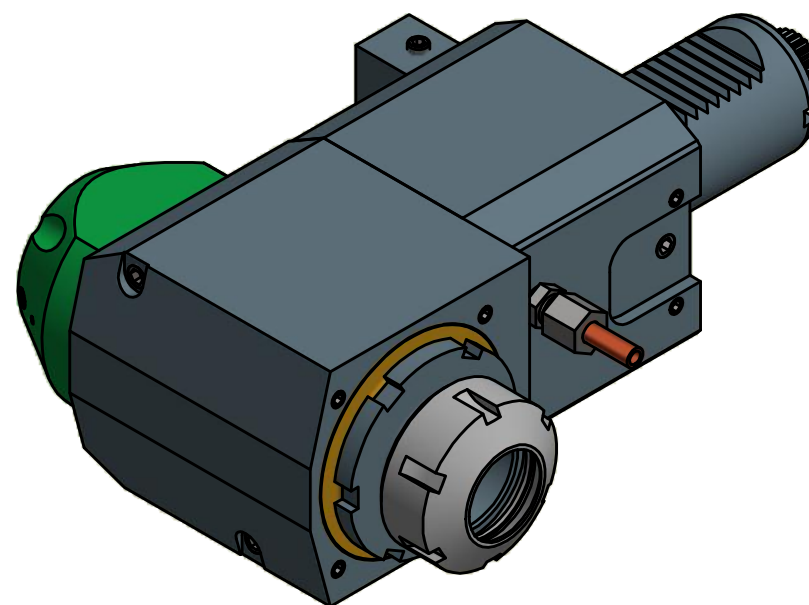
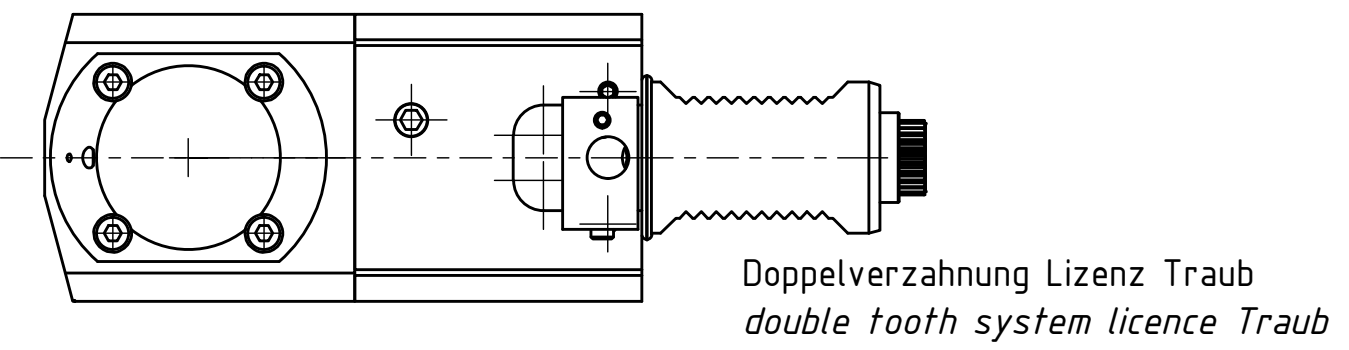
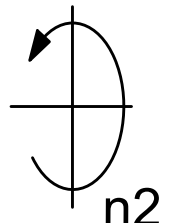

Bemerkung - Note Nicht ohne Kuehlmittel betreiben! Not for use without coolant-fluid!	Technische Daten - technical data Weight = 7.606 [kg]
	Torque max. (M1/M2) = 50 / 25 [Nm]
	Speed max. (n1/n2) = 6000 / 12000 [1/min]
	Gear ratio (i)=n1:n2 = 1:2
	Pressure (pmax) = 70 [bar]

Benennung - Title Radial Bohr und Fräskopf Radial drilling and milling head

EWS Tool Technologies EWS Weigle GmbH & Co. KG Maybachstr. 1 D-73066 Uhlingen www.ews-tools.de	Technische Aenderungen vorbehalten! Subject to technical modifications! IDENT: DEWS120889	MNR. REV: -/A 221495	QR
	Nr. - No. 60.4032LCTXRLIK11DI	Copyright EWS Tool Technologies Weitergabe und Vervielfaeltigung dieser Unterlage, Verwertung und Mitteilung ihres Inhalts nicht gestattet, soweit nicht ausdrecklich zugestanden. Zuwiderhandlungen verpflichten zu Schadenersatz.	