

EWS.Varia Highspeed

Tech Details

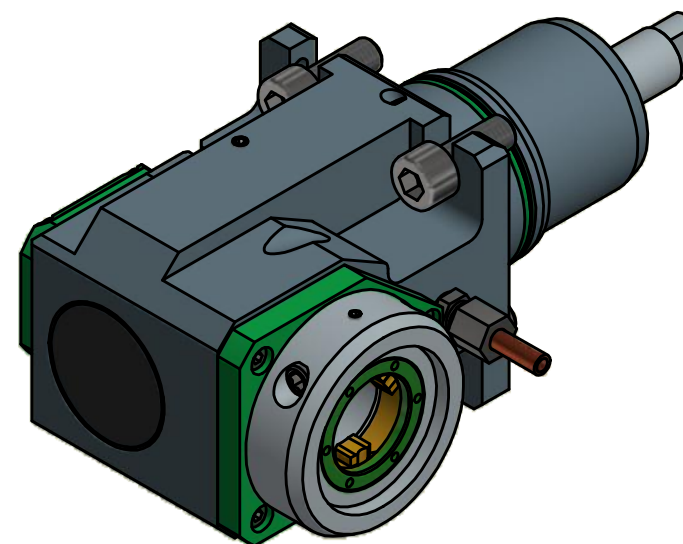
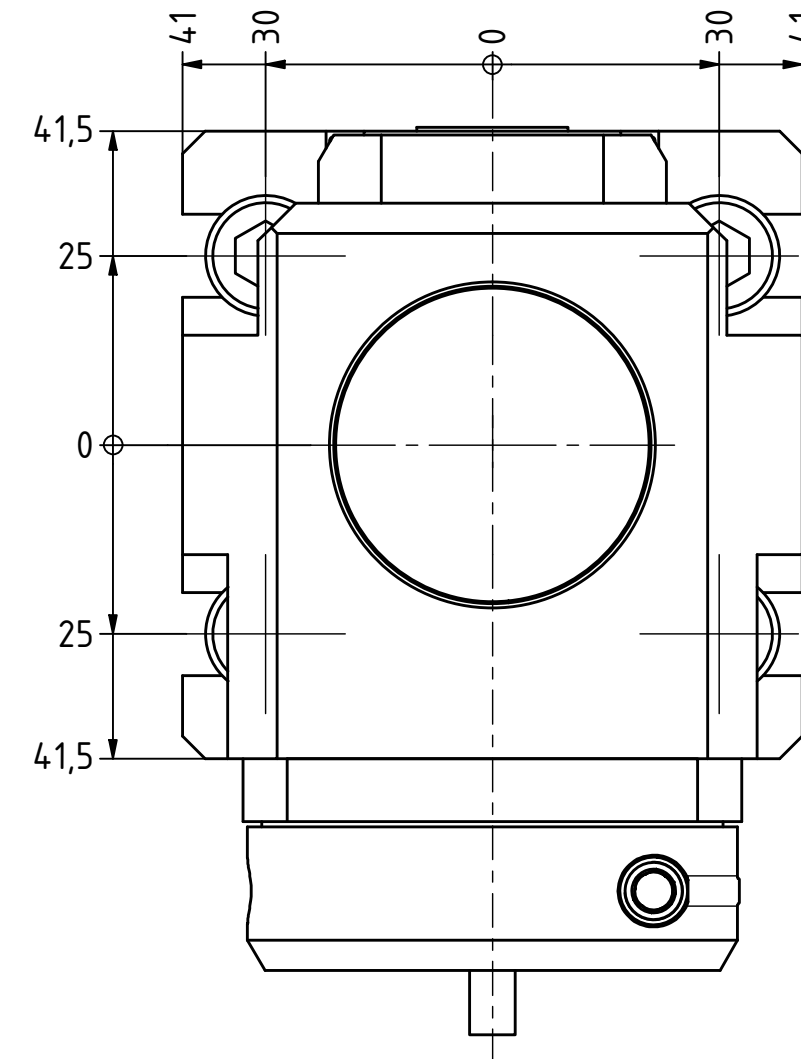
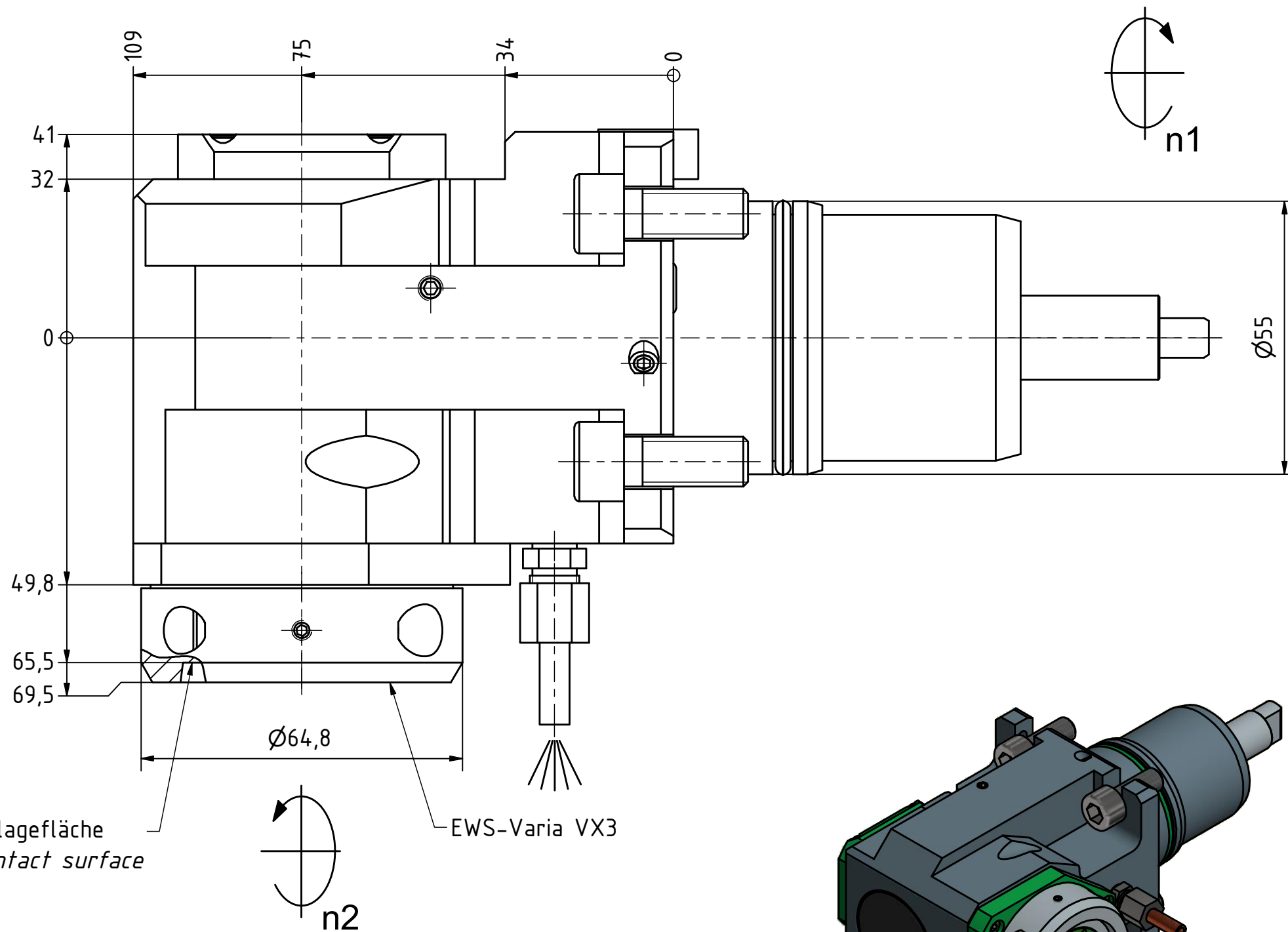

Copyright **EWS Tool Technologies**
 Weitergabe und Vervielfaeltigung dieser Unterlage,
 Verwertung und Mitteilung ihres Inhalts nicht
 gestattet, soweit nicht ausdrecklich zugestanden.
 Zuwiderhandlungen verpflichten zu Schadenersatz.

Bemerkung - Note

Technische Daten - technical data

Benennung - Title

Weight = 5.039 [kg]
 Torque max. (M1/M2) = 24 / 12 [Nm]
 Speed max. (n1/n2) = 6000 / 12000 [1/min]
 Gear ratio (i)=n1:n2 = 1:2

Radial Bohr und Fräskopf
 Radial drilling and milling head



Nr. - No.
 60.55VX3WT250BMT11

Technische Aenderungen vorbehalten!
 Subject to technical modifications!

IDENT: DEWS114.986



REV: -/A

MNR.

221121

