

Spannzange / collet ER25 DIN6499  
 Spannungsbereich / clamping range: 1,0 - 16,0

Gewindebohrzange / tapping collet  
 ET-1-25 M3-M12

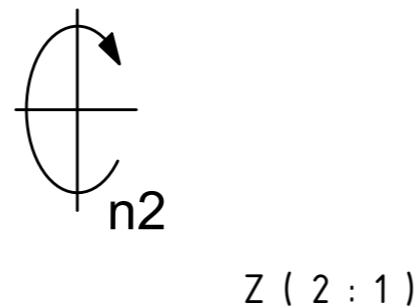

Ausrichtklotz ist über ein Exzenter einstellbar.  
 The block is adjustable via eccentric.

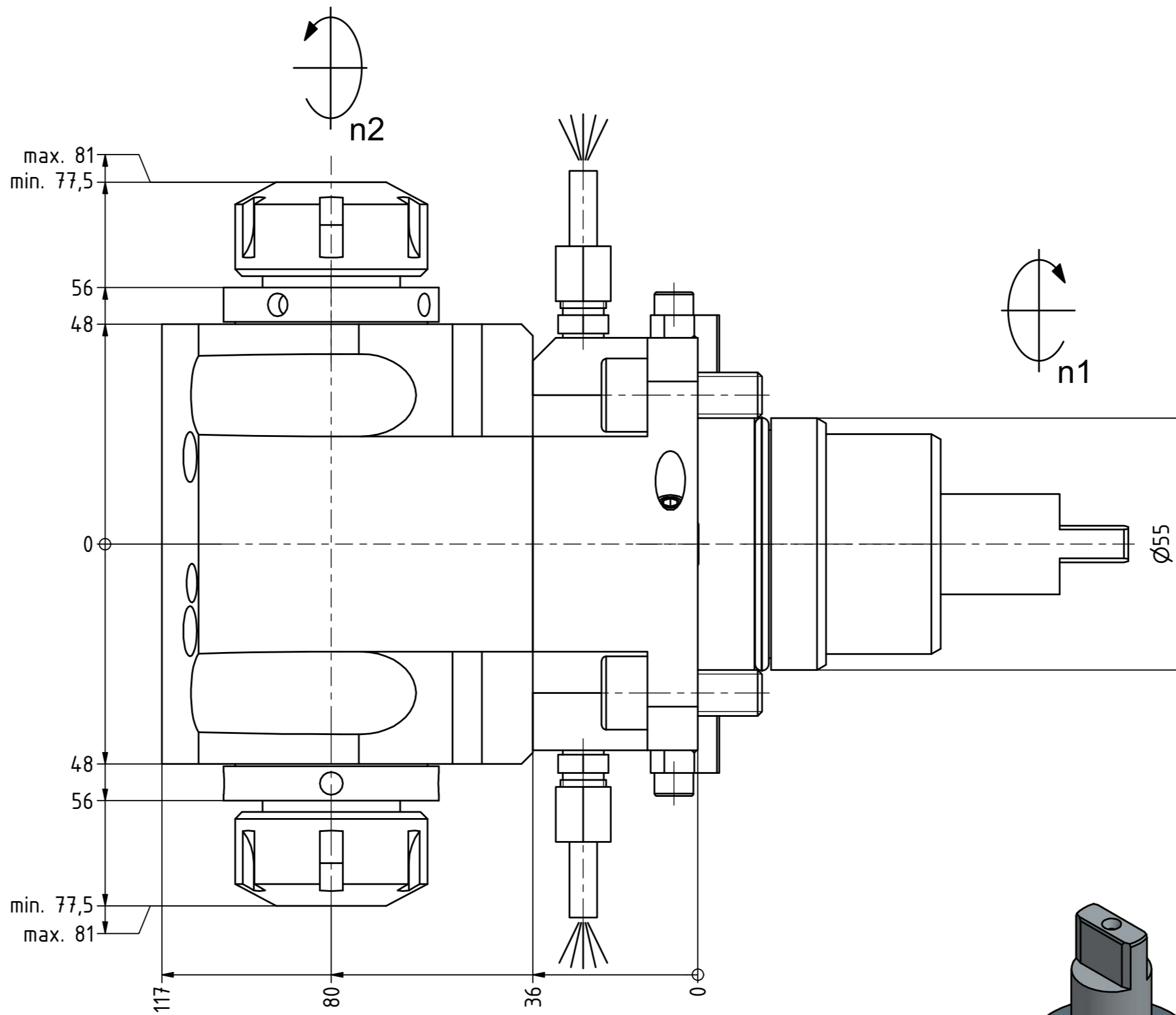
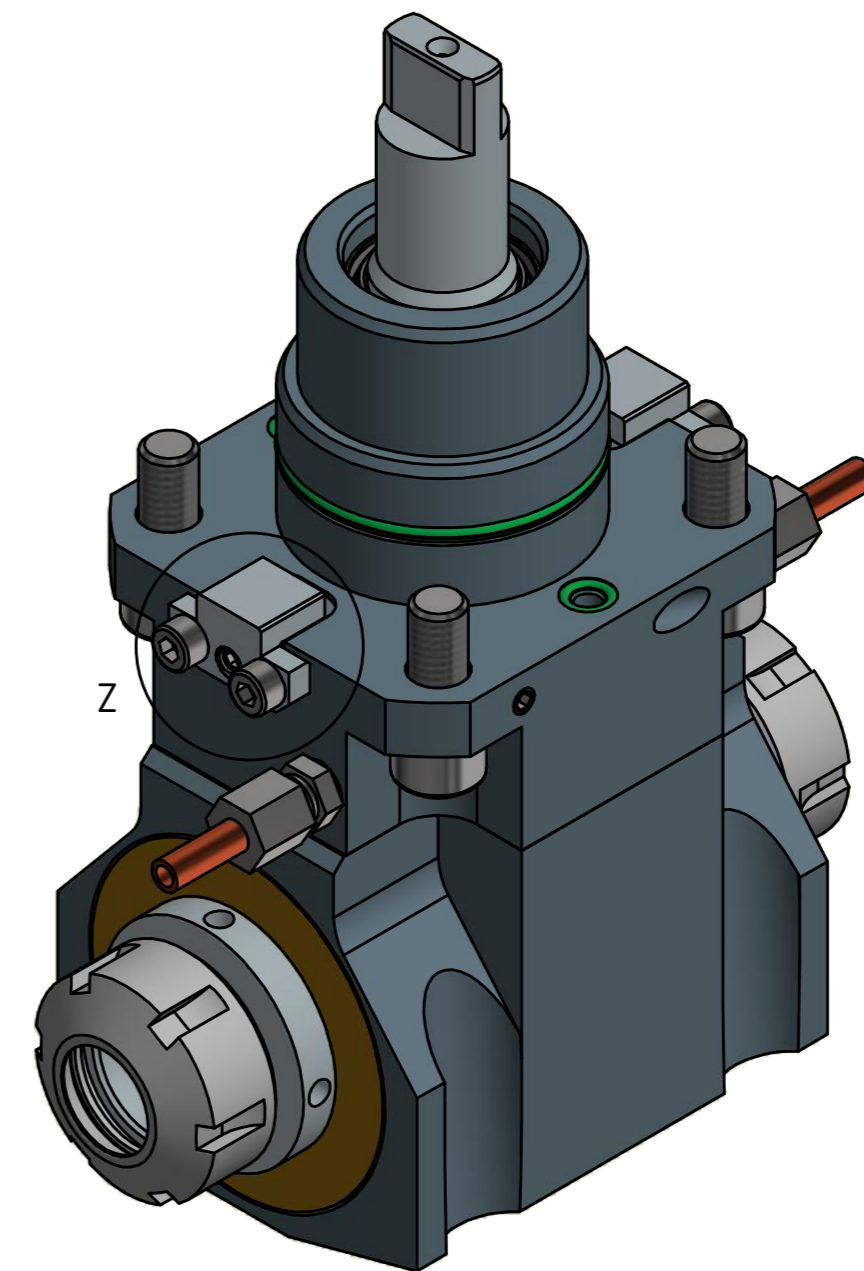
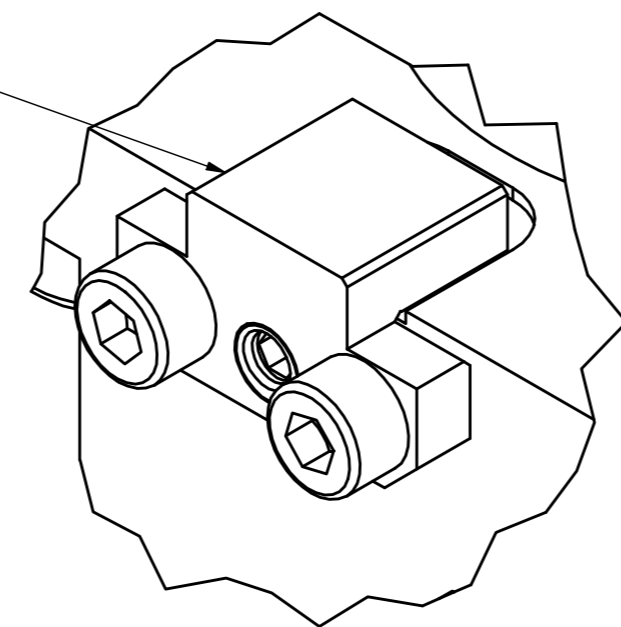

Spannzangenschlüssel  
 Clamping wrench  
 225

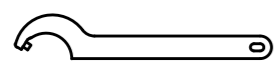

Hakenschlüssel  
 mit Zapfen  
 Hook wrench  
 with fixed pin  
 DIN1810 B 45x50

Bemerkung - Note

Technische Daten - technical data  
 Weight = 6.697 [kg]  
 Torque max. (M1/M2) = 50 / 50 [Nm]  
 Speed max. (n1/n2) = 6000 / 6000 [1/min]  
 Gear ratio (i)=n1:n2 = 1:1

Benennung - Title

Radial Bohr und Fräskopf  
 Radial drilling and milling head



Technische Änderungen vorbehalten!  
 Subject to technical modifications!  
 IDENT: DEWS107535

Nr. - No.  
 60.5525DBIG1809X80

REV: -/A  
 MNR.  
 220069



Copyright EWS Tool Technologies  
 Weitergabe und Vervielfältigung dieser Unterlage,  
 Verwertung und Mitteilung ihres Inhalts nicht  
 gestattet, soweit nicht ausdrücklich zugestanden.  
 Zuwiderhandlungen verpflichten zu Schadenersatz.