

Innen- und Aussenkuehlung / Inside and outside coolant supply  
Kein Trockenlauf / No dry run  
Kuehlmittelfiltrierung-50µ / coolant filtration=50µ

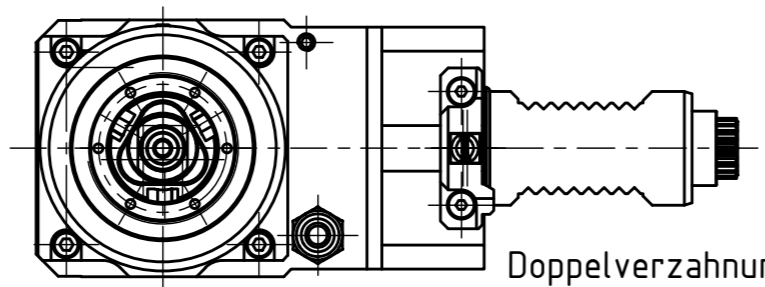

Doppelverzahnung Lizenz Traub  
double tooth system licence Traub

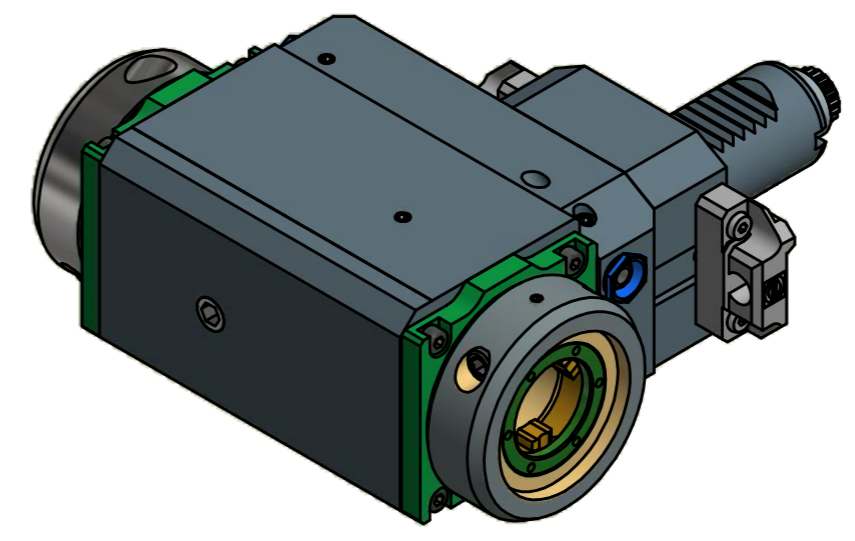

Copyright **EWS Tool Technologies**  
Weitergabe und Vervielfaeltigung dieser Unterlage,  
Verwertung und Mitteilung ihres Inhalts nicht  
gestattet, soweit nicht ausdrecklich zugestanden.  
Zuwoerhandlungen verpflichten zu Schadenersatz.

<p>Benennung - Title</p> <p>Nicht ohne Kuehlmittel betreiben! Not for use without coolant-fluid!</p>	<p>Technische Daten - technical data</p> <p>Weight = 6.418 [kg]</p> <p>Torque max. (M1/M2) = 25 / 25   25 [Nm]</p> <p>Speed max. (n1/n2) = 8000 / 8000   8000 [1/min]</p> <p>Gear ratio (i)=n1:n2 = 1:1   1:1</p> <p>Pressure (pmax) = 25 [bar]</p>	<p>Benennung - Title</p> <p>Radial Bohr und Fräskopf, zurückges Radial drill. and mill. head offset</p>	<p><b>EWS</b> Tool Technologies</p> <p>EWS Weigle GmbH &amp; Co. KG Maybachstr. 1 D-73066 Uhlingen www.ews-tool.de</p> <p>Technische Aenderungen vorbehalten! Subject to technical modifications!</p> <p>IDENT: DEWS108286</p> <p>REV: -/A</p> <p>MNR.</p> <p>80.30VX3DGT300RLIKTFR</p> <p>220091</p>	<p>QR</p>
--	---	---	---	-----------