

Spannzange / collet ER32 DIN6499
 Spannungsbereich / clamping range: 2,0 - 20,0

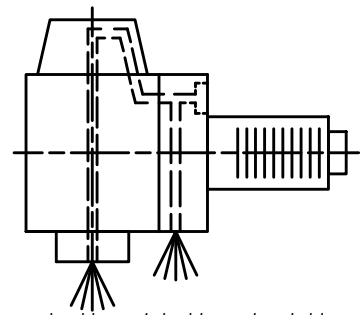

Innen- und Aussenkuehlung / Inside and outside coolant supply
 Kuehlmittelfiltrierung <math>< 50\mu</math> / coolant filtration <math>< 50\mu</math>

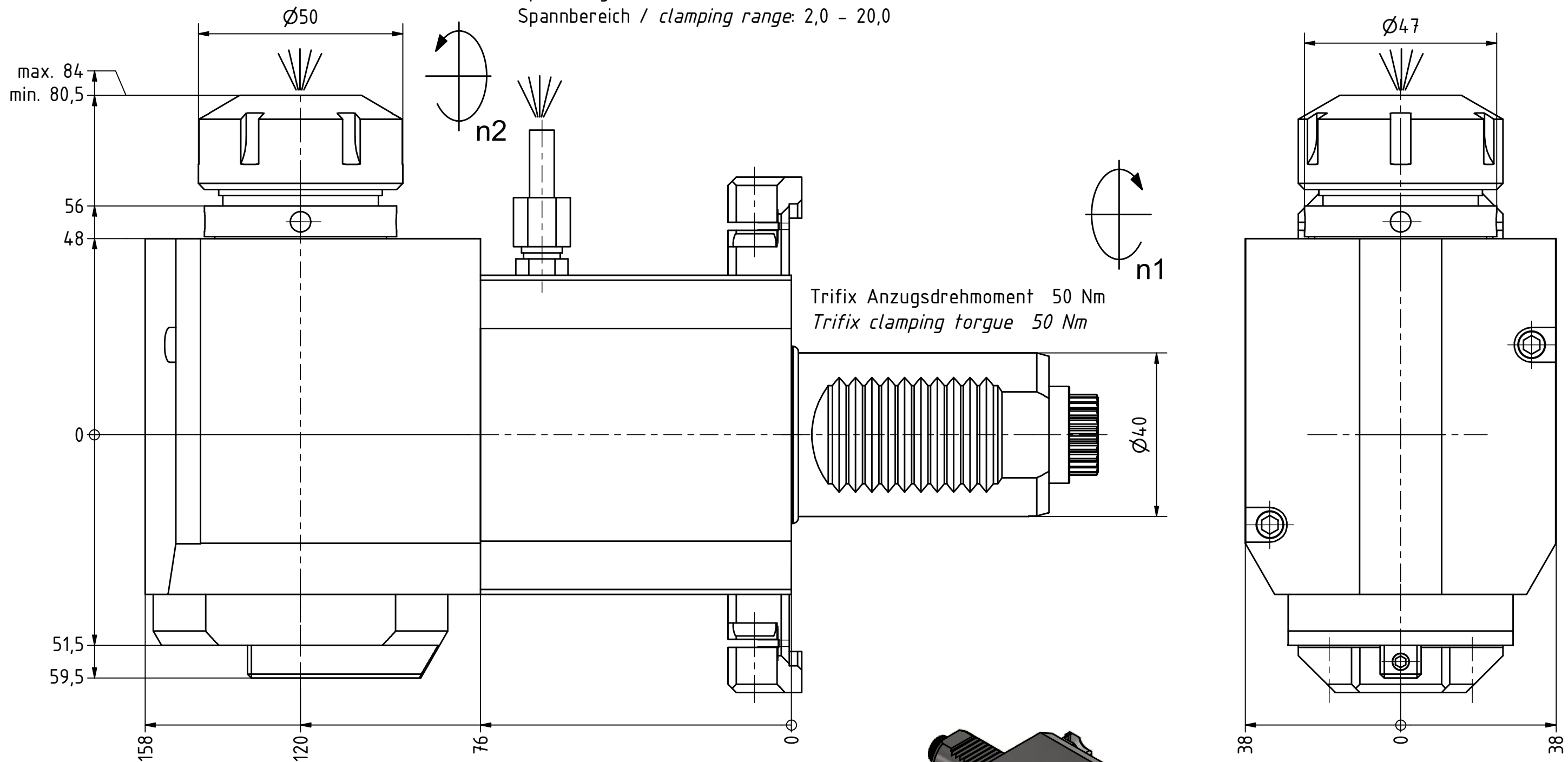
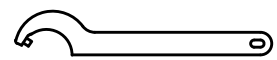

Hakenschlüssel
 mit Zapfen
 Hook wrench
 with fixed pin
 DIN1810 B 45x50

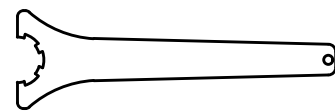

Spannzangenschlüssel
 Clamping wrench
 232

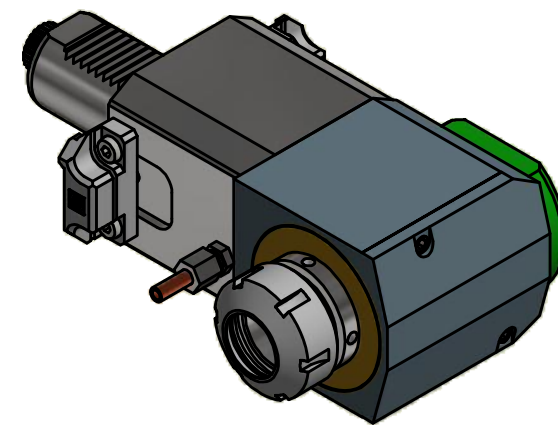

Copyright **EWS Tool Technologies**
 Weitergabe und Vervielfaeltigung dieser Unterlage,
 Verwertung und Mitteilung ihres Inhalts nicht
 gestattet, soweit nicht ausdrecklich zugestanden.
 Zuwiderhandlungen verpflichten zu Schadenersatz.

Bemerkung - Note
 Für Trockenlauf geeignet!
 Use without coolant fluid allowed!

Technische Daten - technical data	
Weight	= 7,316 [kg]
Torque max. (M1/M2)	= 50 / 50 [Nm]
Speed max. (n1/n2)	= 6000 / 6000 [1/min]
Gear ratio (i)=n1:n2	= 1:1
Pressure (pmax)	= 70 [bar]

Benennung - Title
Radial Bohr und Fräskopf
 Radial drilling and milling head



Nr. - No.
 60.4032LCTXLIKDTF

Technische Aenderungen vorbehalten!
 Subject to technical modifications!
 IDENT: DEWS103281



REV: -/A

MNR.
 219242

