

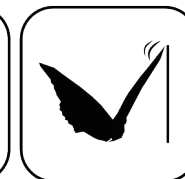

EWS.Varia



Ceramic Seal



Butterfly Seal



Tech Details

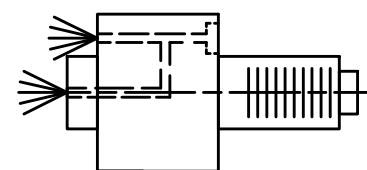
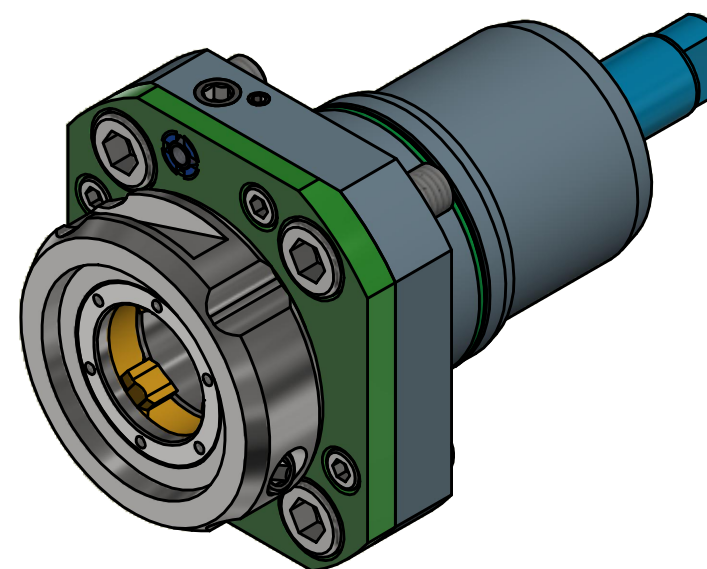
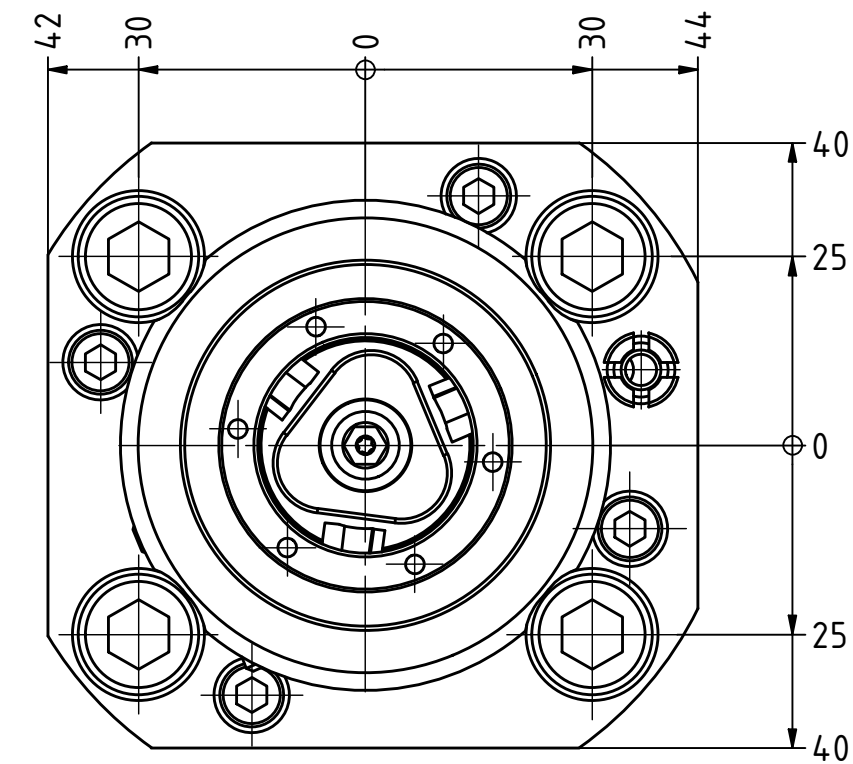
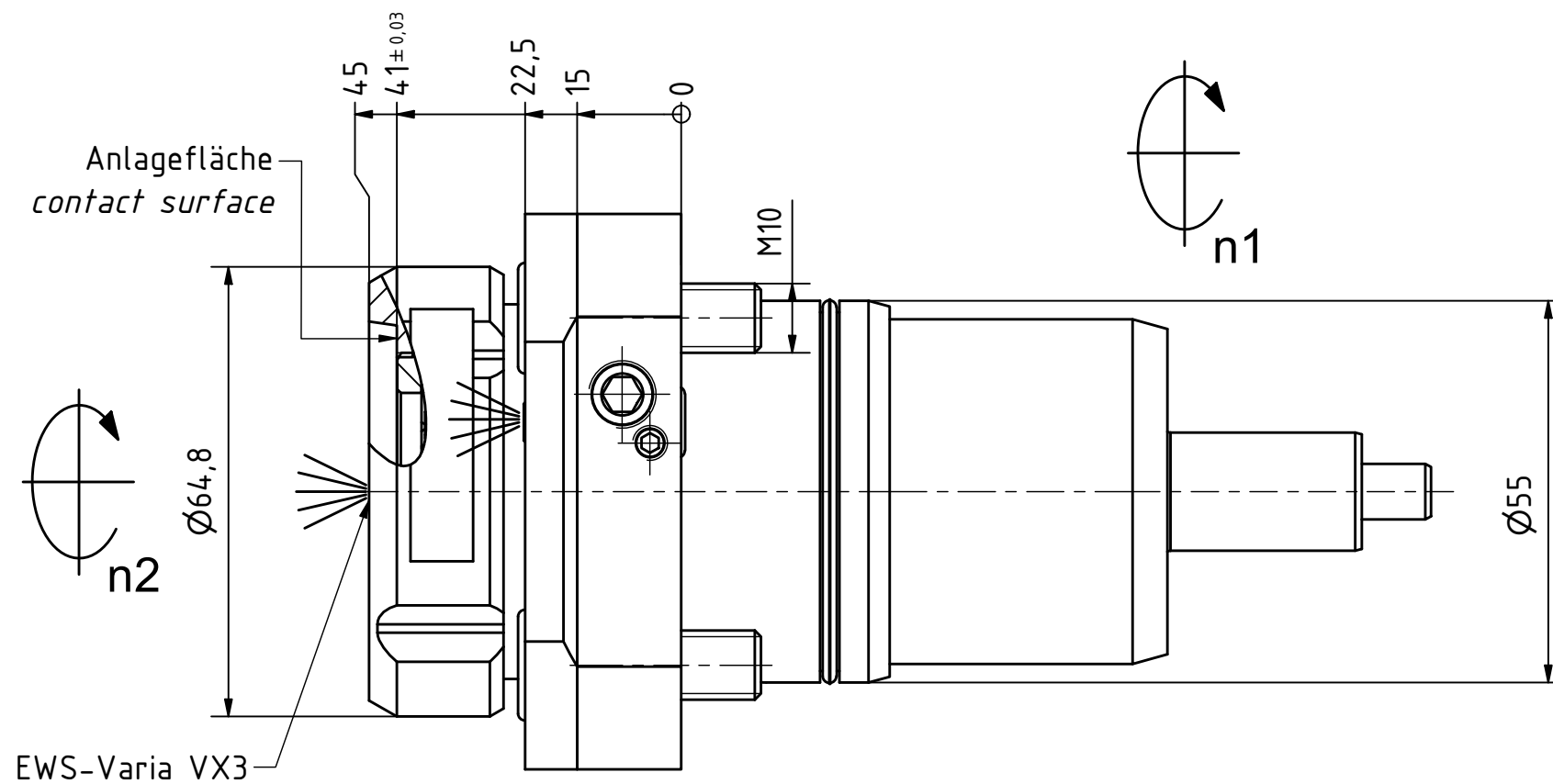

Innen- und Aussenkuehlung / Inside and outside coolant supply
Kuehlmittelfiltrierung<50µ / coolant filtration<50µ

Copyright **EWS Tool Technologies**
Weitergabe und Vervielfaeltigung dieser Unterlage,
Verwertung und Mitteilung ihres Inhalts nicht
gestattet, soweit nicht ausdrecklich zugestanden.
Zuwiderhandlungen verpflichten zu Schadenersatz.

Bemerkung - Note

Für Trockenlauf geeignet!
Use without coolant fluid allowed!

Technische Daten - technical data

Weight = 2.467 [kg]
Torque max. (M1/M2) = 25 / 25 [Nm]
Speed max. (n1/n2) = 6000 / 6000 [1/min]
Gear ratio (i)=n1:n2 = 1:1
Pressure (pmax) = 70 [bar]

Benennung - Title

Axial Bohr und Fräskopf
Axial drilling and milling head

EWS
Tool Technologies
EWS Weigle GmbH & Co. KG
Maybachstr. 1
D-73066 UHINGEN
www.ews-tools.de

Technische Aenderungen vorbehalten!
Subject to technical modifications!

IDENT: DEWS146683



REV: -/D

Nr. - No.

40.55VX3TW10IKC-ET

MNR.

219529

QR