

Innen- und Aussenkuehlung / Inside and outside coolant supply
Kuehlmittelfiltrierung=50µ / coolant filtration=50µ

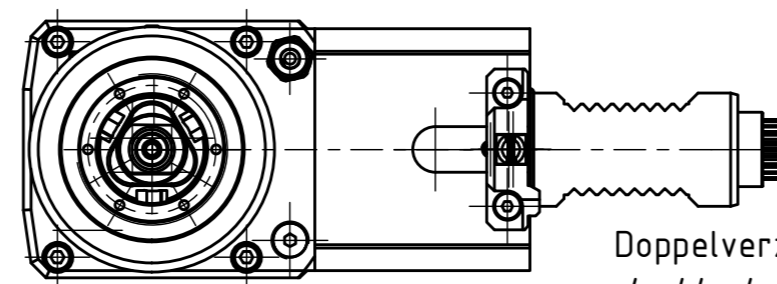

Doppelverzahnung Lizenz Traub
double tooth system licence Traub

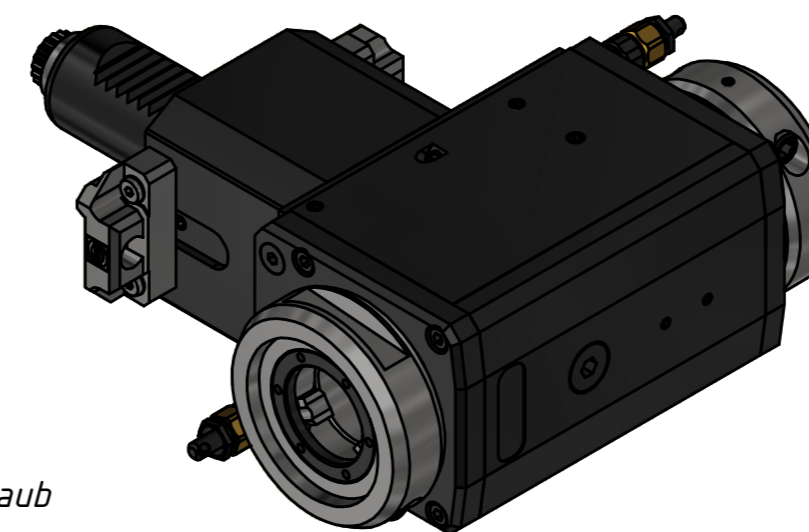

Copyright **EWS Tool Technologies**
Weitergabe und Vervielfaeltigung dieser Unterlage,
Verwertung und Mitteilung ihres Inhalts nicht
gestattet, soweit nicht ausdrecklich zugestanden.
Zuwiderhandlungen verpflichten zu Schadenersatz.

<p>Bemerkung - Note</p> <p>Für Trockenlauf geeignet! Use without coolant fluid allowed!</p>	<p>Technische Daten - technical data</p> <p>Weight = 6.760 [kg]</p> <p>Torque max. (M1/M2) = 32 / 32 32 [Nm]</p> <p>Speed max. (n1/n2) = 8000 / 8000 8000 [1/min]</p> <p>Gear ratio (i)=n1:n2 = 1:1 1:1</p> <p>Pressure (pmax) = 70 [bar]</p>	<p>Benennung - Title</p> <p>Radial Bohr und Fräskopf Radial drilling and milling head</p>	<p>EWS EWS Weigle GmbH & Co. KG Maybachstr. 1 D-73066 Uhlingen www.ews-tool.de</p> <p>Technische Aenderungen vorbehalten! Subject to technical modifications!</p> <p>IDENT: DEWS268761</p> <p>REV: -/D</p> <p>Nr. - No. 60.30VX3LDCTXRLIKTFL</p> <p>MNR. 219312</p> <p>QR</p>
---	---	---	---