

min. 63,5
max. 67

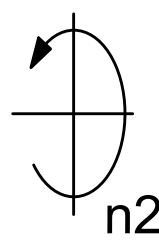

Spannzange / *collet* ER25 DIN6499
Spannbereich / *clamping range*: 1,0 - 16,0

Gewindebohrzange / *tapping collet*
ET-1-25 M3-M12

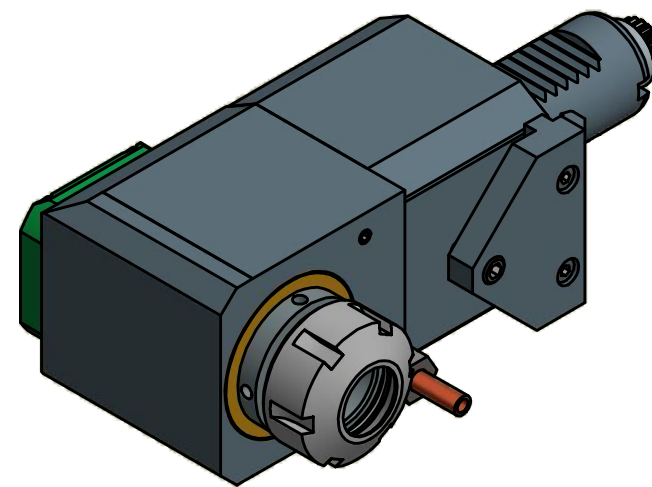
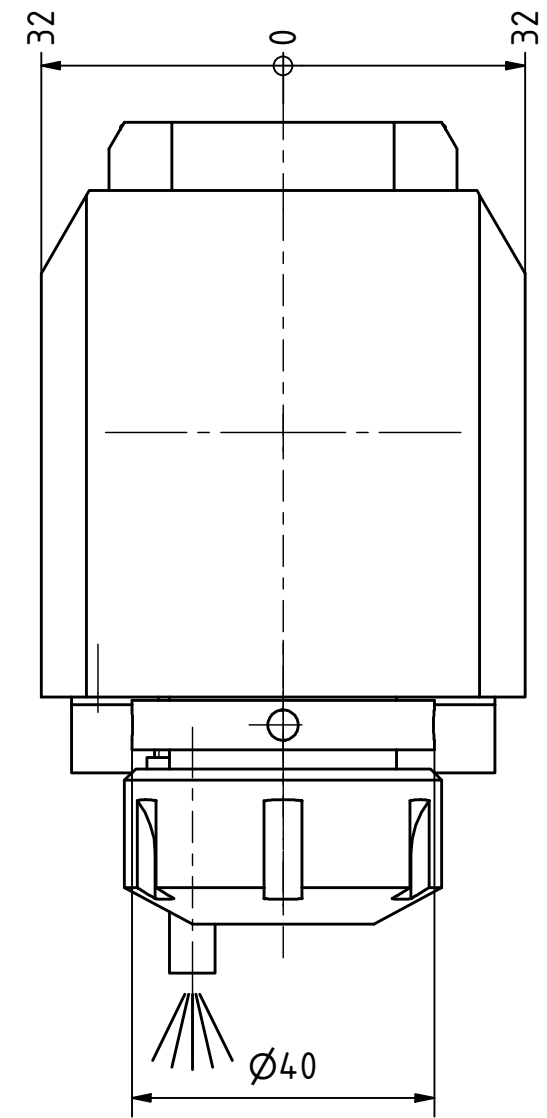

Hakenschlüssel
mit Zapfen
Hook wrench
with fixed pin
DIN1810 B 40x42



Spannzangenschlüssel
Clamping wrench
225

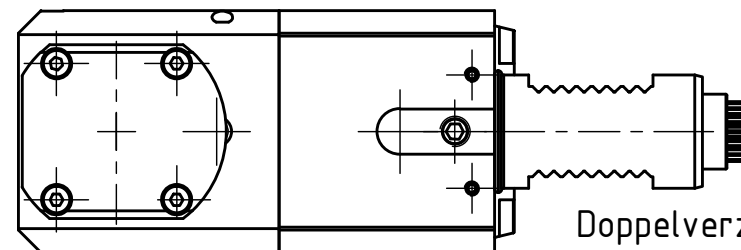

Doppelverzahnung Lizenz Traub
double tooth system licence Traub

Copyright **EWS Tool Technologies**
Weitergabe und Vervielfaeltigung dieser Unterlage,
Verwertung und Mitteilung ihres Inhalts nicht
gestattet, soweit nicht ausdrecklich zugestanden.
Zuwiderhandlungen verpflichten zu Schadenersatz.

Bemerkung - *Note*

Technische Daten - *technical data*

Weight = 4.051 [kg]
Torque max. (M1/M2) = 25 / 25 [Nm]
Speed max. (n1/n2) = 8000 / 8000 [1/min]
Gear ratio (i)=n1:n2 = 1:1

Benennung - *Title*

Radial Bohr und Fräskopf
Radial drilling and milling head

EWS
Tool Technologies

EWS Weigele GmbH & Co. KG
Maybachstr. 1
D-73066 UHINGEN
www.ews-tools.de

Technische Aenderungen vorbehalten!
Subject to technical modifications!

IDENT: DEWS101761

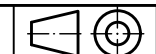

REV: -/A

Nr. - *No.*

60.3025E365RLEL

MNR.

218937

QR