

Innen- und Aussenkuehlung / Inside and outside coolant supply
Kuehlmittelfiltrierung+50µ / coolant filtration+50µ

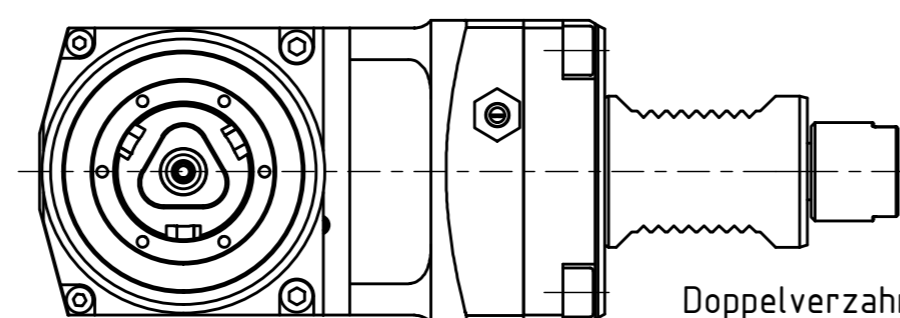

Doppelverzahnung Lizenz Traub
double tooth system licence Traub

Bemerkung - Note Für Trockenlauf geeignet! Use without coolant fluid allowed!	Technische Daten - technical data Weight = 11050 [kg]
	Torque max. (M1/M2) = 50 / 50 50 [Nm]
	Speed max. (n1/n2) = 6000 / 6000 6000 [1/min]
	Gear ratio (i)=n1:n2 = 1:1 1:1
	Pressure (pmax) = 70 [bar]

Benennung - Title
Radial Bohr und Fräskopf
Radial drilling and milling head

EWS Tool Technologies <small>EWS Weigle GmbH & Co. KG Maybachstr. 1 D-73066 Ulm/Ingen www.ews-tool.de</small>	Technische Änderungen vorbehalten! Subject to technical modifications! IDENT: DEWS100547	MNR. REV: -/B
	Nr. - No. 60.40VX4DG250RLIKDWX110	218474

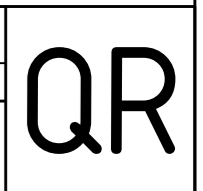

Copyright **EWS Tool Technologies**
 Weitergabe und Vervielfältigung dieser Unterlage,
 Verwertung und Mitteilung ihres Inhalts nicht
 gestattet, soweit nicht ausdrücklich zugestanden.
 Zuwiderhandlungen verpflichten zu Schadenersatz.