

Schwenkbereich ±105°
Swivel area ±105°

Spannzange / collet ER25 DIN6499
Spannbereich / clamping range: 1,0 - 16,0

Gewindebohrzange / tapping collet
ET-1-25 M3-M10

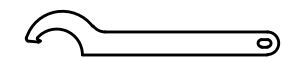
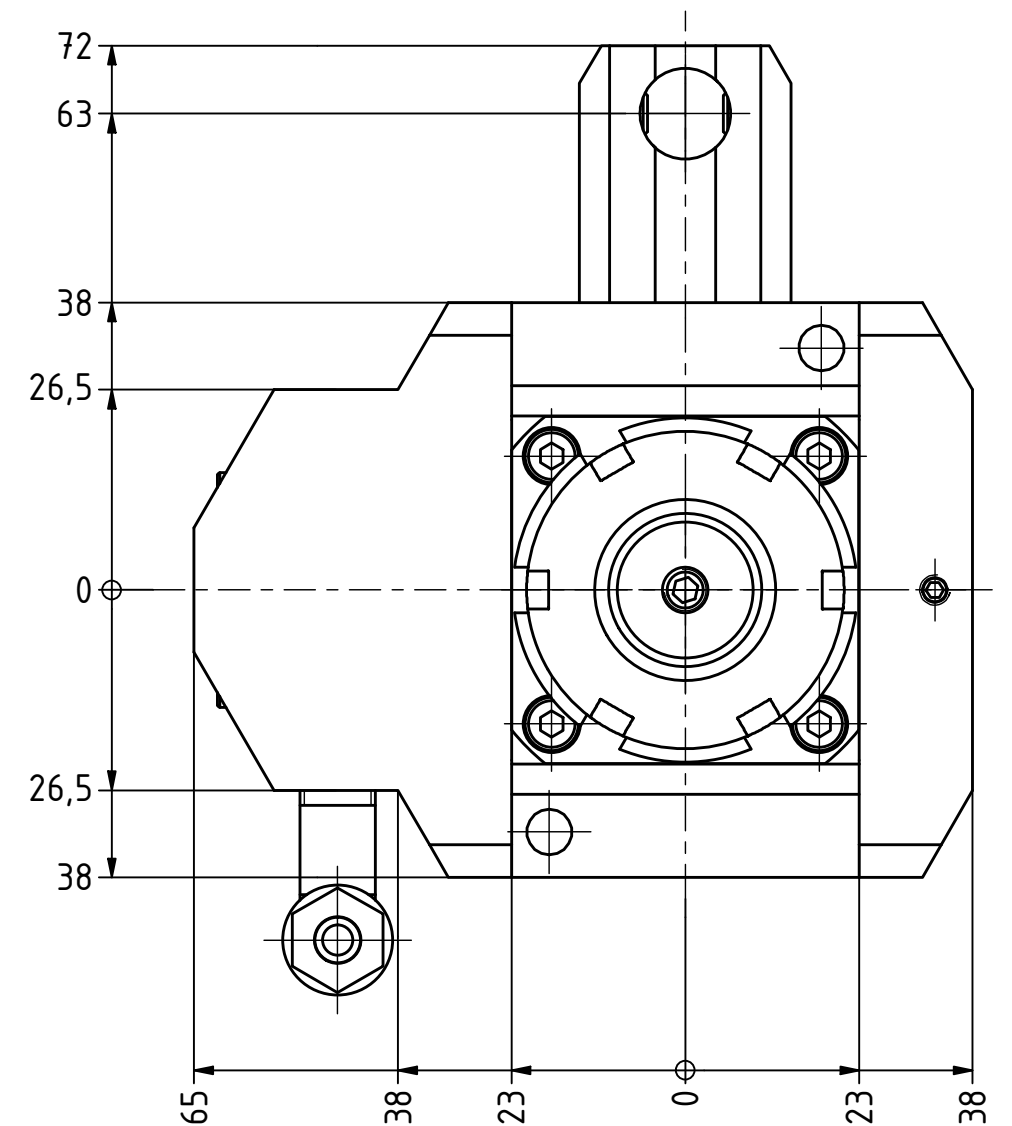
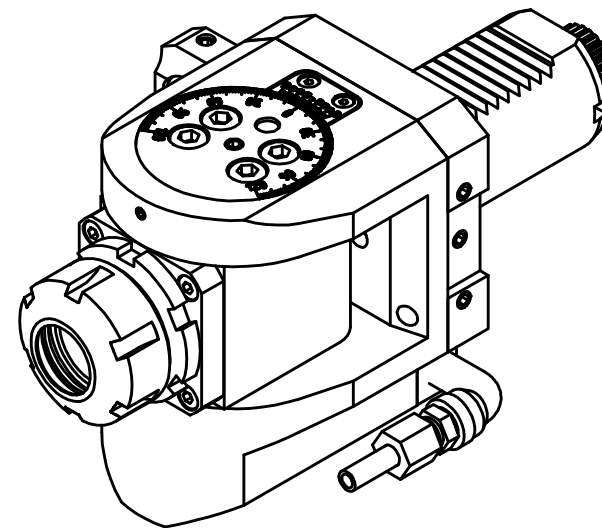

Hakenschlüssel
mit Nase
Hook wrench with
nose end
DIN1810 A 45x50

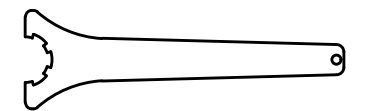

Spannzangenschlüssel
Clamping wrench
225

Copyright **EWS Tool Technologies**
Weitergabe und Vervielfaeltigung dieser Unterlage,
Verwertung und Mitteilung ihres Inhalts nicht
gestattet, soweit nicht ausdrecklich zugestanden.
Zuwiderhandlungen verpflichten zu Schadenersatz.

Bemerkung - Note

Technische Daten - technical data

Weight = 4.361 [kg]
Torque max. (M1/M2) = 20 / 20 [Nm]
Speed max. (n1/n2) = 10000 / 10000 [1/min]
Gear ratio (i)=n1:n2 = 1:1

Benennung - Title

Schwenkkopf
Swivel head

EWS
Tool Technologies

EWS Weigle GmbH & Co. KG
Maybachstr. 1
D-73066 UHINGEN
www.ews-tools.de

Technische Aenderungen vorbehalten!
Subject to technical modifications!

IDENT: DEWS100962



REV: -/A

Nr. - No.

63.4025CTXPIN63

MNR.

217549

QR