

Spannzange / Collet ER16 DIN6499
 Spannungsbereich / Clamping range: 1,0 - 10,0

Gewindebohrzange / Tapping Collet
 ET-1-16 M1-M6

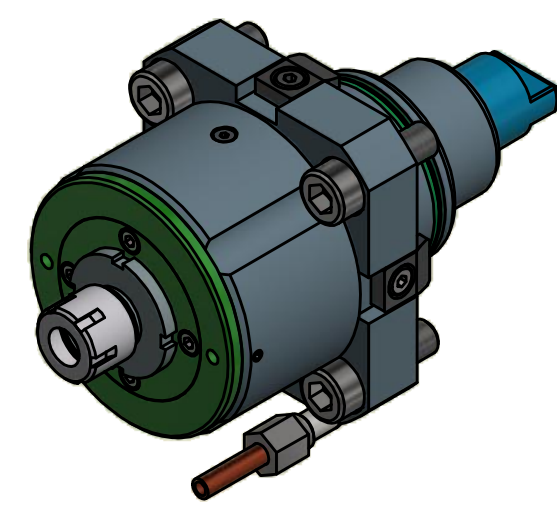

Fettschmierung mit Klüber Isoflex NCA 15
 Alle 100 Betriebsstunden mit ca. 1cm³ Fett nachschmieren
*Grease lubrication with Klüber Isoflex NCA 15
 relubricate every 100 operating hours with about 1cm³ of grease*

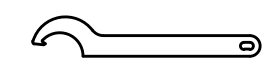

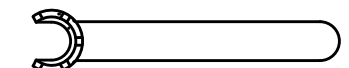
 Hakenschlüssel
 mit Nase
 Hook wrench with
 nose end
 DIN1810 A 36x38

 Spannzangenschlüssel
 Clamping wrench
 216 M

Copyright **EWS Tool Technologies**
 Weitergabe und Vervielfältigung dieser Unterlage,
 Verwertung und Mitteilung ihres Inhalts nicht
 gestattet, soweit nicht ausdrücklich zugestanden.
 Zuwiderhandlungen verpflichten zu Schadenersatz.

Bemerkung - Note	Technische Daten - technical data Weight = 3.288 [kg] Torque max. (M1/M2) = 25 / 5 [Nm] Speed max. (n1/n2) = 4800 / 24000 [1/min] Gear ratio (i)=n1:n2 = 1:5	Benennung - Title Axial Bohr und Fräskopf Axial drilling and milling head	 EWS Weigele GmbH & Co. KG Maybachstr. 1 D-73066 UHINGEN www.ews-tools.de	Technische Änderungen vorbehalten! Subject to technical modifications! IDENT: DEWS093821 Nr. - No. 40.5516VL2115-COB	 REV: -/B MNR. 217111	
------------------	--	---	---	--	---	---