

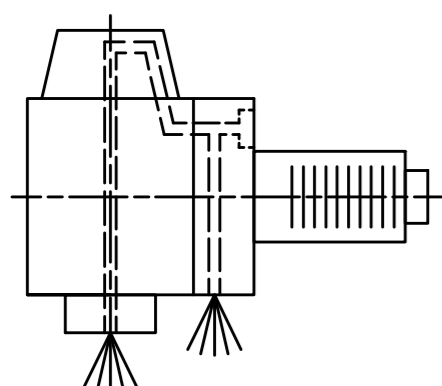

EWS.Varia

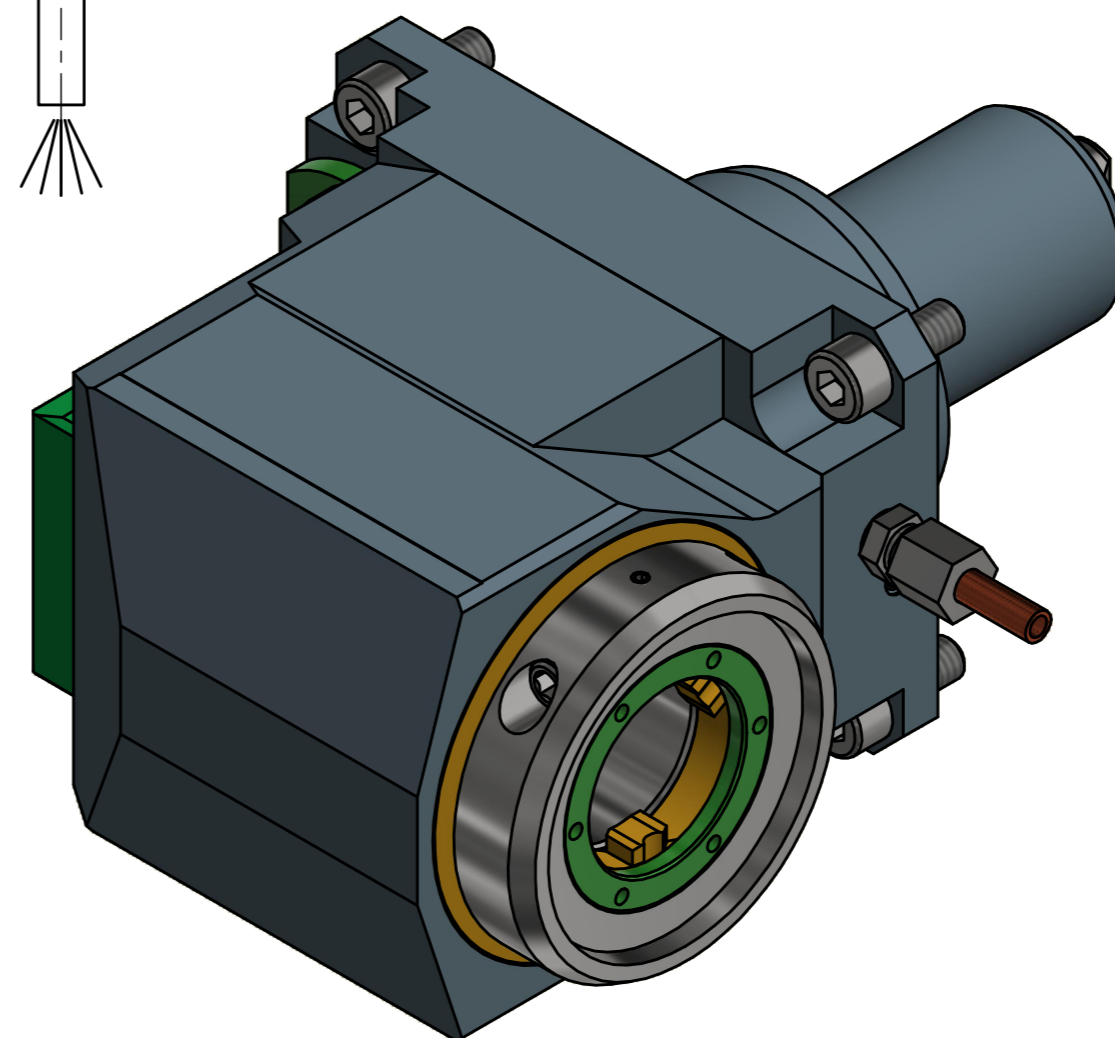

Tech
Details

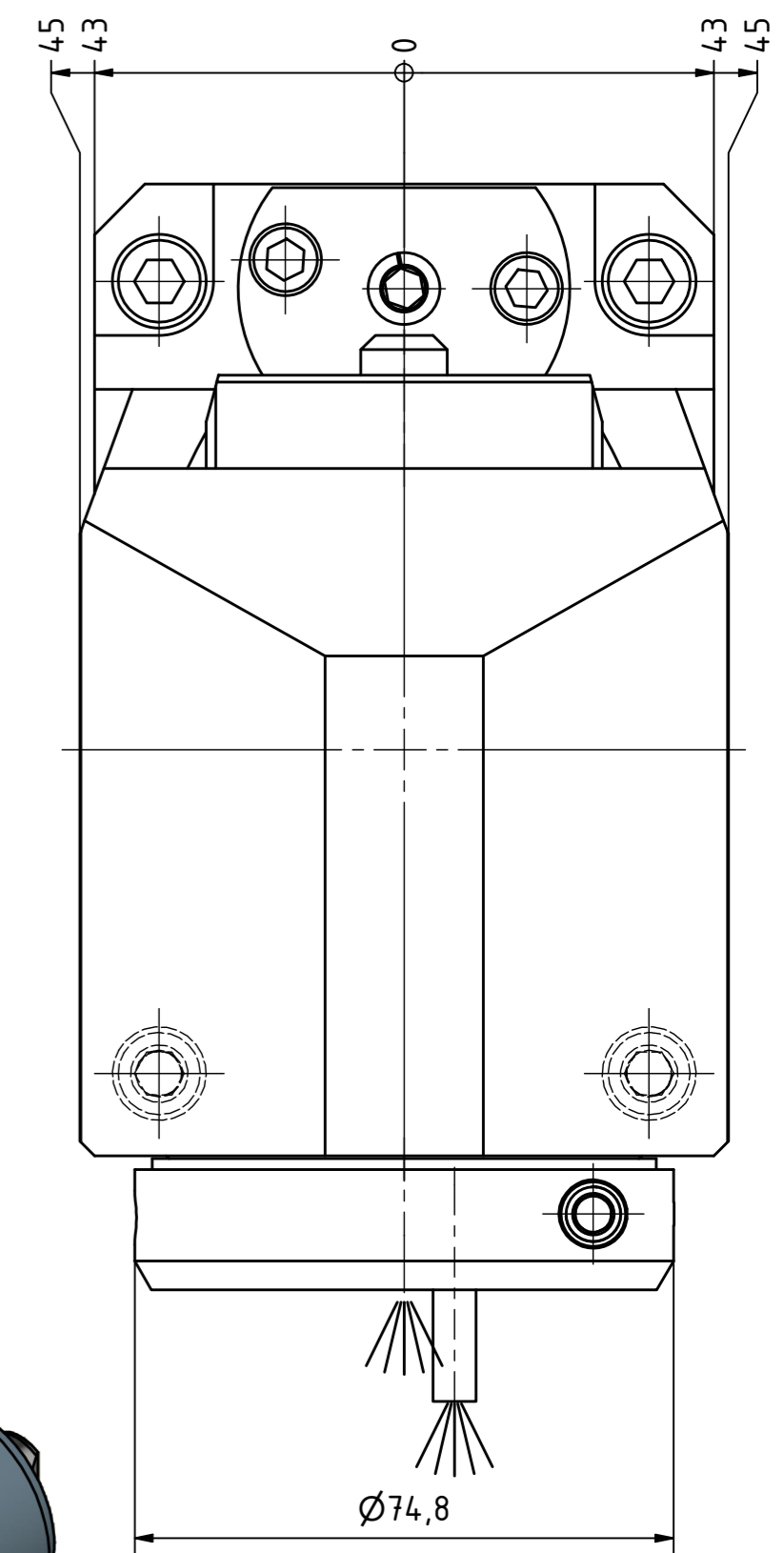
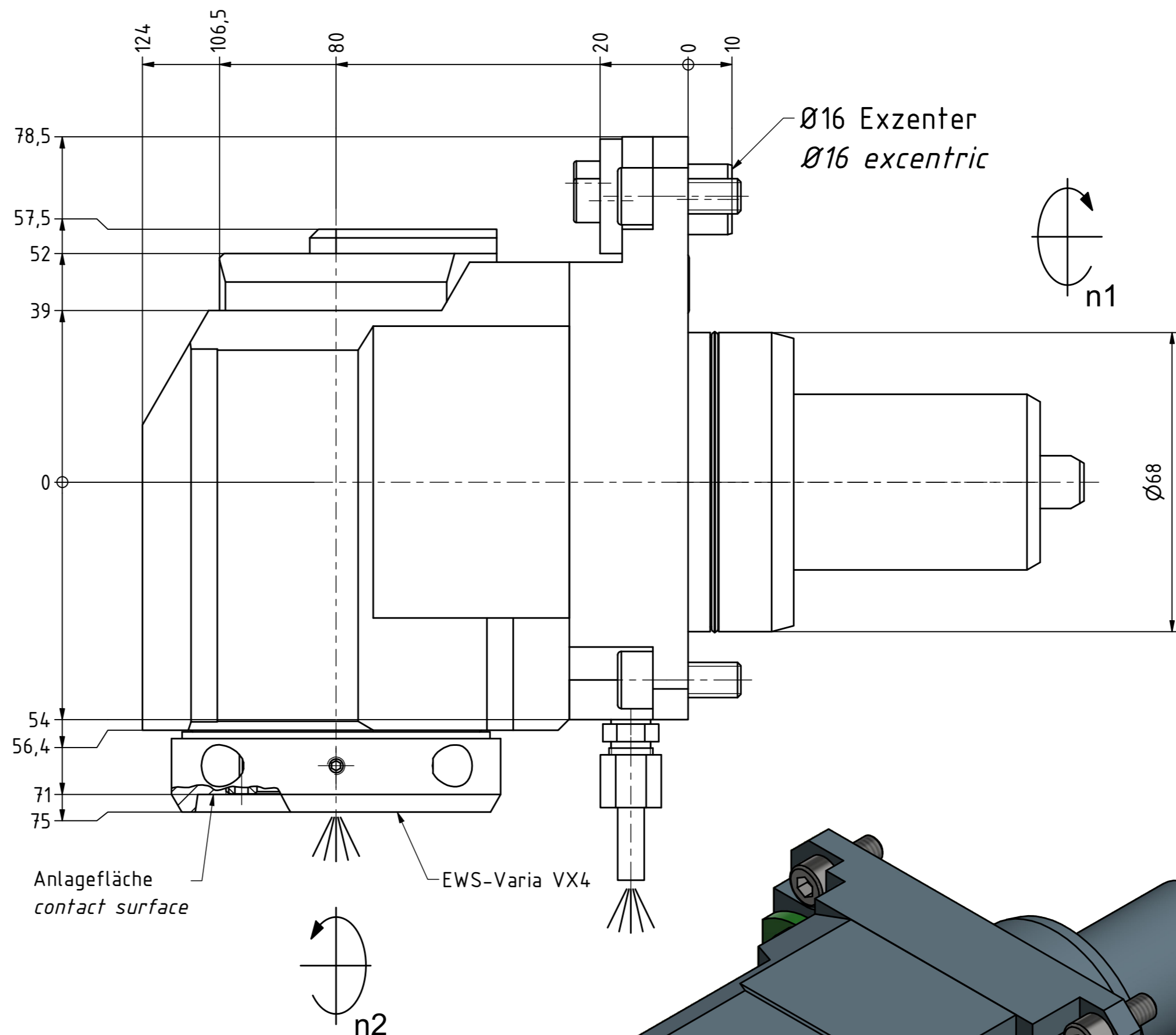
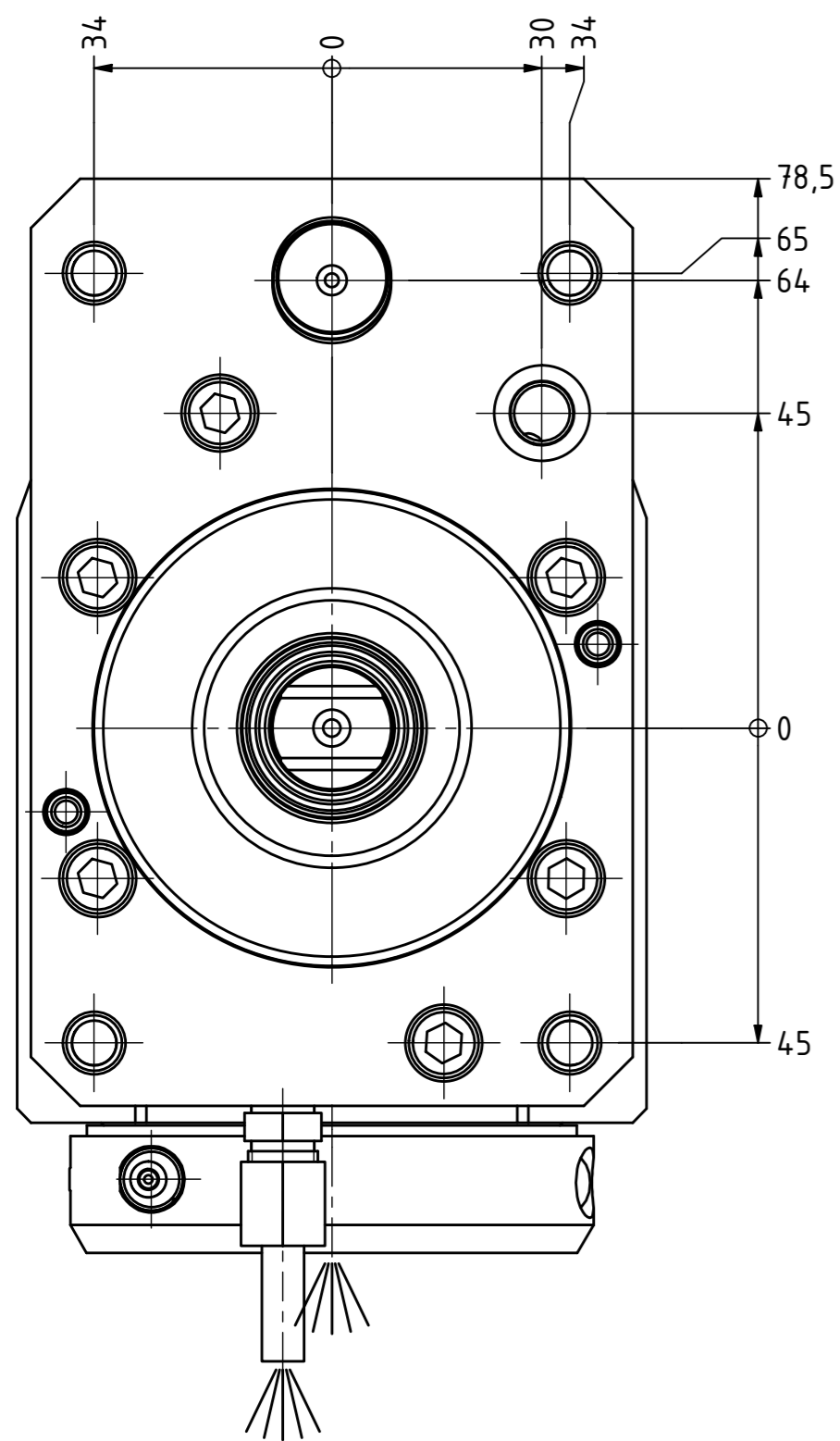

Innen- und Aussenkuehlung / Inside and outside coolant supply
Kuehlmittelfiltrierung<50µ / coolant filtration<50µ

Bemerkung - Note
Für Trockenlauf geeignet!
Use without coolant fluid allowed!
mit Kegelrollenlager
with taper roller bearing(s)

Technische Daten - technical data
Weight = 8.597 [kg]
Torque max. (M1/M2) = 50 / 50 [Nm]
Speed max. (n1/n2) = 5000 / 5000 [1/min]
Gear ratio (i)=n1:n2 = 1:1
Pressure (pmax) = 70 [bar]

Benennung - Title
Radial Bohr und Fräskopf
Radial drilling and milling head

EWS Tool Technologies
EWS Weigle GmbH & Co. KG
Maybachstr. 1
D-73066 Uhlingen
www.ews-tool.de
Technische Änderungen vorbehalten!
Subject to technical modifications!
IDENT: DEWS123268
REV: -/D
MNR.
187156



Copyright **EWS Tool Technologies**
Weitergabe und Vervielfältigung dieser Unterlage,
Verwertung und Mitteilung ihres Inhalts nicht
gestattet, soweit nicht ausdrücklich zugestanden.
Zuwendungen verpflichten zu Schadenersatz.