

Spannzange / collet ER40 DIN6499
Spannbereich / clamping range: 3,0 - 26,0

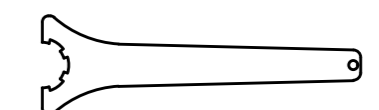

Spannzangenschlüssel
Clamping wrench
240

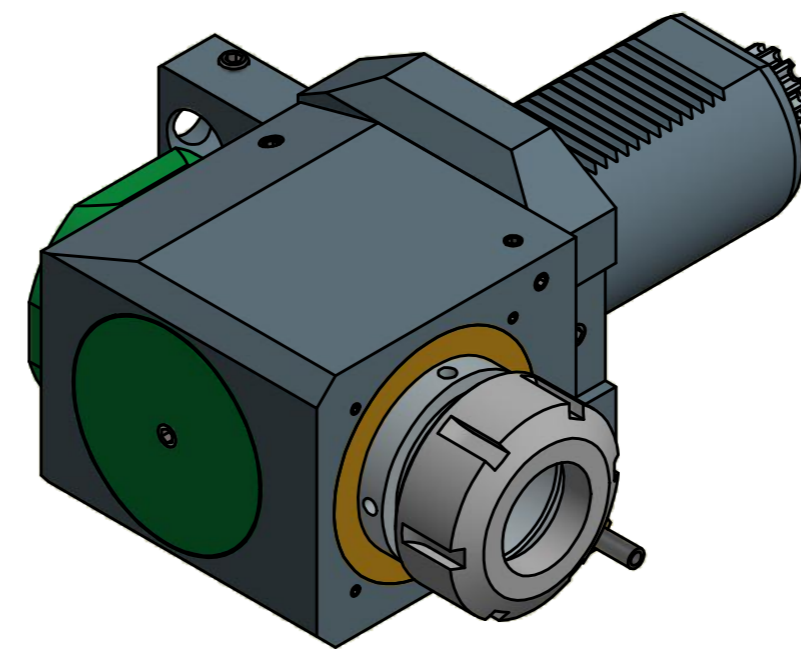
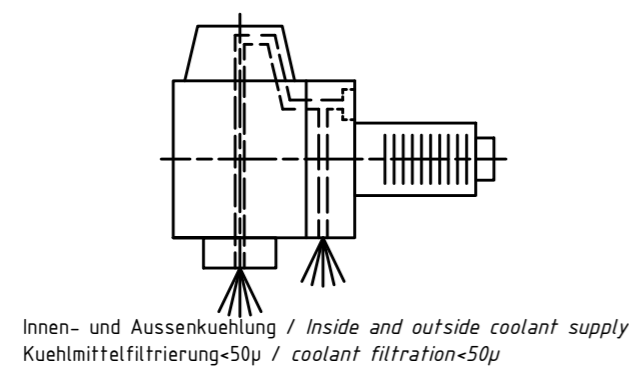
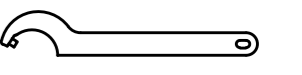

Hakenschlüssel
mit Zapfen
Hook wrench
with fixed pin
DIN1810 B 58x62

Copyright **EWS Tool Technologies**
Weitergabe und Vervielfaeltigung dieser Unterlage,
Verwertung und Mitteilung ihres Inhalts nicht
gestattet, soweit nicht ausdrecklich zugestanden.
Zuwiderhandlungen verpflichten zu Schadenersatz.

Bemerkung - Note
Für Trockenlauf geeignet!
Use without coolant fluid allowed!

Technische Daten - technical data
Weight = 9.432 [kg]
Torque max. (M1/M2) = 160 / 160 [Nm]
Speed max. (n1/n2) = 3000 / 3000 [1/min]
Gear ratio (i)=n1:n2 = 1:1
Pressure (pmax) = 70 [bar]

Benennung - Title
Radial Bohr und Fräskopf
Radial drilling and milling head

EWS Tool Technologies
EWS Weigle GmbH & Co. KG
Maybachstr. 1
D-73066 Uhlingen
www.ews-tools.de
Nr. - No.
60.604.05482RIKD

Technische Aenderungen vorbehalten!
Subject to technical modifications!
IDENT: D-EWS-163386

REV: -/-
MNR.

177261

QR