



EWS.Varia



Ceramic Seal



Tech Details

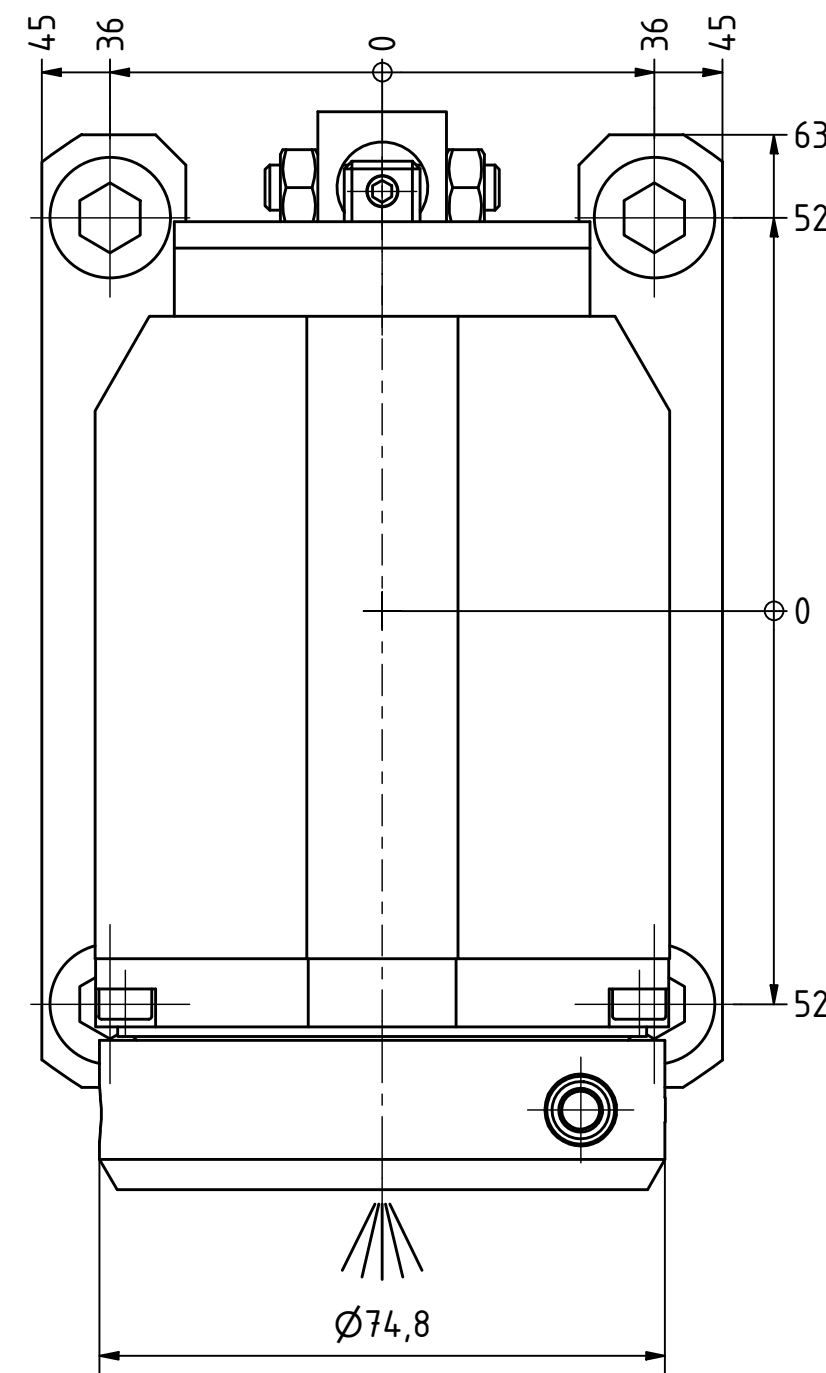
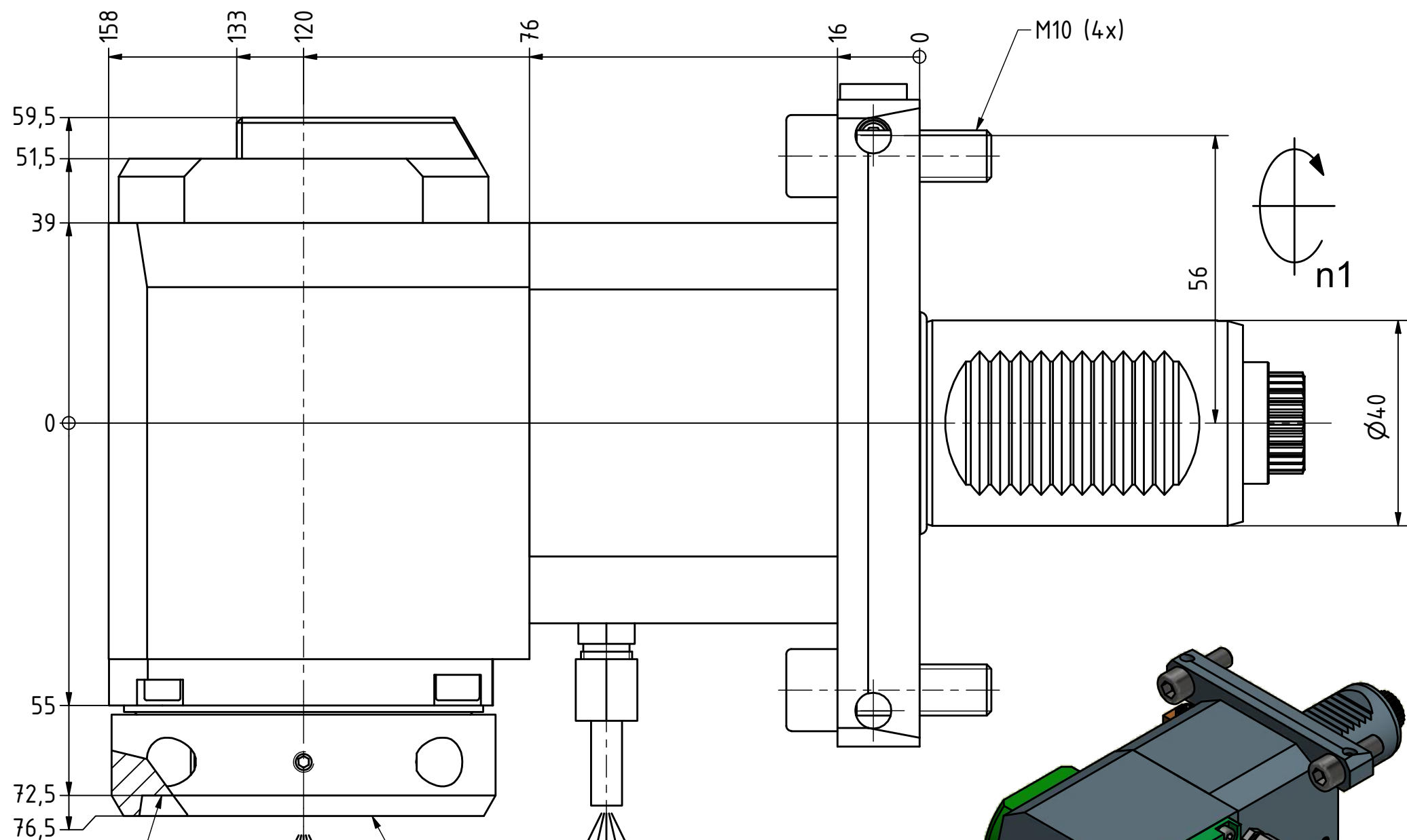

Anlagefläche
contact surface

EWS-Varia VX4

Doppelverzahnung Lizenz Traub
double tooth system licence Traub

Bemerkung - Note
Für Trockenlauf geeignet!
Use without coolant fluid allowed!

Technische Daten - technical data

Weight = 8,032 [kg]
 Torque max. (M1/M2) = 50 / 50 [Nm]
 Speed max. (n1/n2) = 6000 / 6000 [1/min]
 Gear ratio (i)=n1:n2 = 1:1
 Pressure (pmax) = 70 [bar]

Benennung - Title

Radial Bohr und Fräskopf
Radial drilling and milling head



Nr. - No.

60.40VX4LCTXRLIKD-PL

Technische Änderungen vorbehalten!
Subject to technical modifications!

IDENT: DEWS115405



REV: -/A

MNR.

221177



Copyright **EWS Tool Technologies**
Weitergabe und Vervielfältigung dieser Unterlage,
Verwertung und Mitteilung ihres Inhalts nicht
gestattet, soweit nicht ausdrücklich zugestanden.
Zuwendungen verpflichten zu Schadenersatz.