

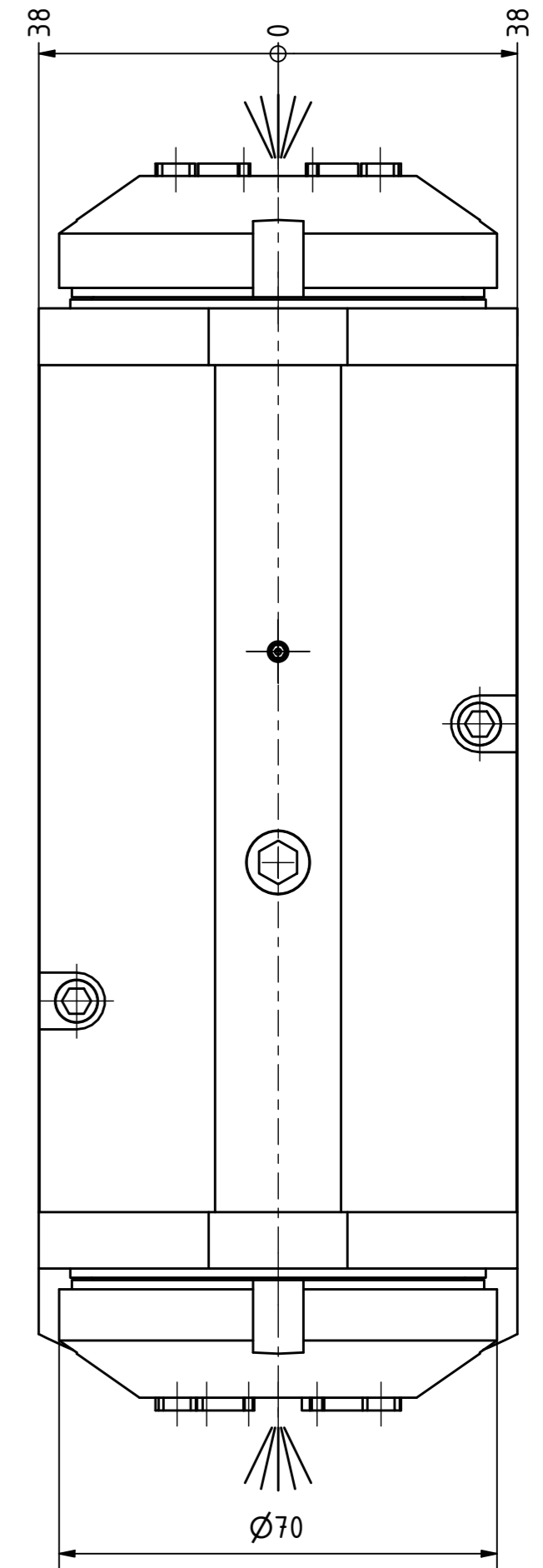

Ceramic Seal

Tech Details

Spannzange / collet ER32 DIN6499
Spannbereich / clamping range: 2,0 - 20,0

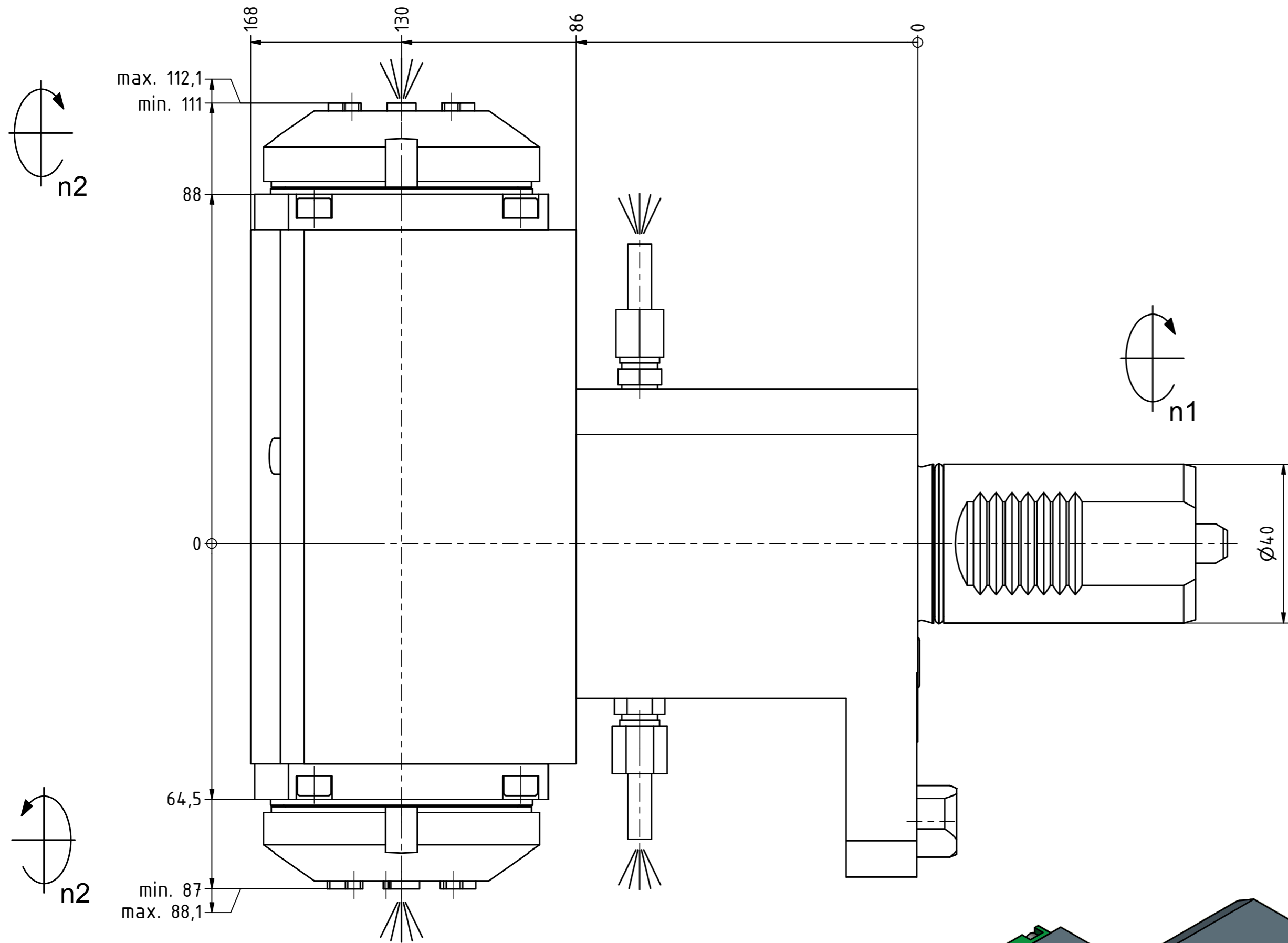

Spannzange / collet ER32 DIN6499
Spannbereich / clamping range: 2,0 - 20,0

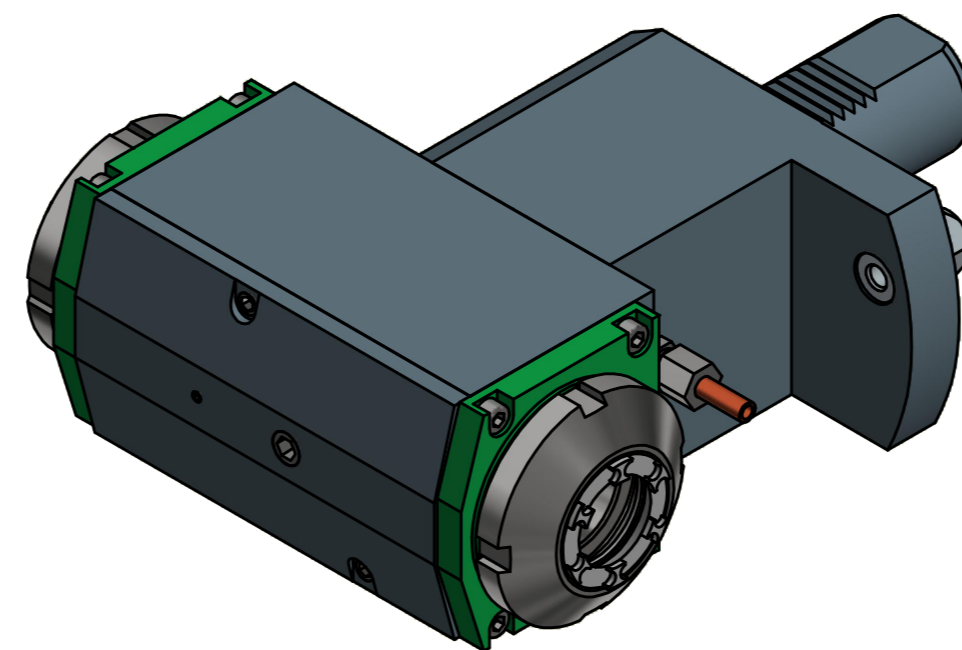

Hakenschlüssel mit Nase
Hook wrench with nose end
DIN1810 A 68x75

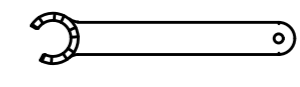

Spannzangenschlüssel für innenliegende Mutter
Clamping wrench for internal collet
232AX

Copyright EWS Tool Technologies
Weitergabe und Vervielfältigung dieser Unterlage, Verwertung und Mitteilung ihres Inhalts nicht gestattet, soweit nicht ausdrücklich zugestanden. Zuwiderhandlungen verpflichten zu Schadenersatz.

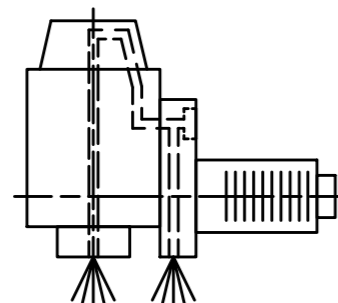

Innen- und Aussenkuehlung / Inside and outside coolant supply
Kuehlmittelfiltrierung=50µ / coolant filtration=50µ

Bemerkung - Note
Für Trockenlauf geeignet!
Use without coolant fluid allowed!

Technische Daten - technical data
Weight = 11,295 [kg]
Torque max. (M1/M2) = 50 / 50 | 50 [Nm]
Speed max. (n1/n2) = 6000 / 6000 | 6000 [1/min]
Gear ratio (i)=n1:n2 = 1:1 | 1:1
Pressure (pmax) = 70 [bar]

Benennung - Title
Radial Bohr und Fräskopf
Radial drilling and milling head

EWS Tool Technologies
EWS Weigle GmbH & Co. KG
Maybachstr. 1
D-73066 Ulm/ingen
www.ews-tool.de
Nf. - No.
60.4032DMP620IKDIM

Technische Änderungen vorbehalten!
Subject to technical modifications!
IDENT: DEWS116007
REV: -/A
MNR.
221243

