

Spannzangenschlüssel für innenliegende Mutter
Clamping wrench for internal collet
232AX

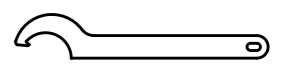

Hakenschlüssel mit Nase
Hook wrench with nose end
DIN1810 A 58x62

Bitte überprüfen Sie, ob der Werkzeughalter auf ihrem Revolver im Maschinenraum ohne Kollision durchschwenken kann. Bitte überprüfen Sie auch die Maße 100,5 und 106mm.

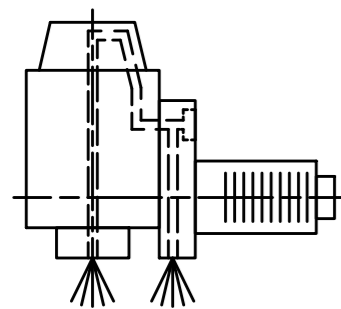

Please check the work space of the machine for interferences with the tool holder, especially the swiveling diameter. Please check also the value 100,5 und 106mm.



Innen- und Aussenkuehlung / Inside and outside coolant supply
Kuehlmittelfiltrierung=50µ / coolant filtration=50µ

| | |
|---|--|
| Bemerkung - Note Für Trockenlauf geeignet! Use without coolant fluid allowed! | Technische Daten - technical data Weight = 8.150 [kg] Torque max. (M1/M2) = 50 / 50 [Nm] Speed max. (n1/n2) = 6000 / 6000 [1/min] Gear ratio (i)=n1:n2 = 1:1 Pressure (pmax) = 70 [bar] |
|---|--|

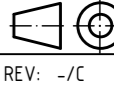
Benennung - Title
Radial Bohr und Fräskopf, zurückges
Radial drill. and mill. head offset

| | | | |
|--|--|---|---|
|  EWS Weigle GmbH & Co. KG Maybachstr. 1 D-73066 Ulm/ingen www.ews-tool.de | Technische Änderungen vorbehalten! Subject to technical modifications! IDENT: DEWS112397 |  REV: -/C MNR. 220709 |  |
| Nr. - No. 80.5532VL2IKDIM | | | |

Copyright EWS Tool Technologies
 Weitergabe und Vervielfältigung dieser Unterlage, Verwertung und Mitteilung ihres Inhalts nicht gestattet, soweit nicht ausdrücklich zugestanden. Zuwiderhandlungen verpflichten zu Schadenersatz.