

Spannzange / collet ER32 DIN6499
Spannbereich / clamping range: 2,0 - 20,0

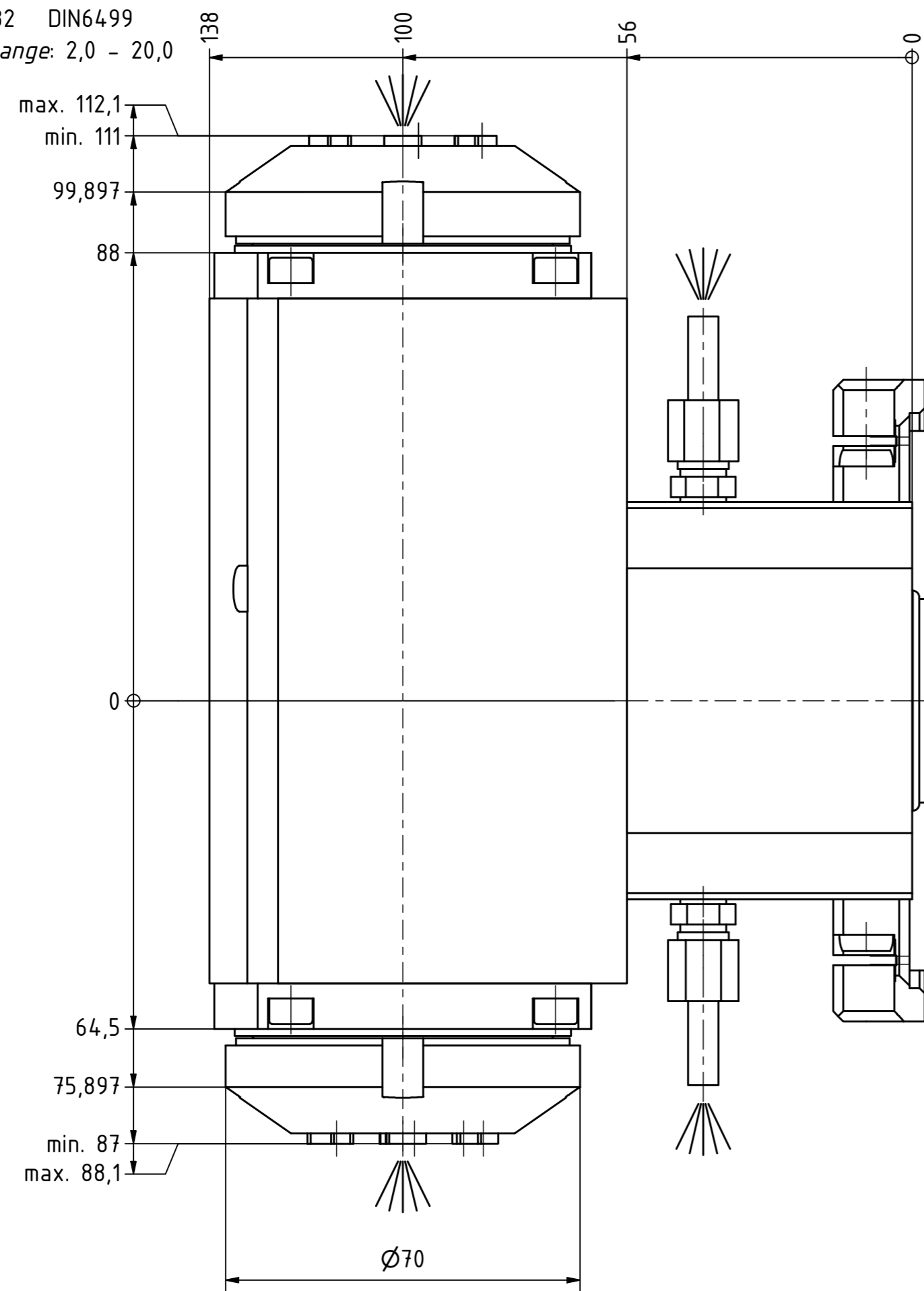

Trifix Anzugsdrehmoment 50 Nm
Trifix clamping torque 50 Nm

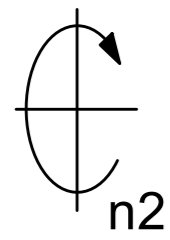
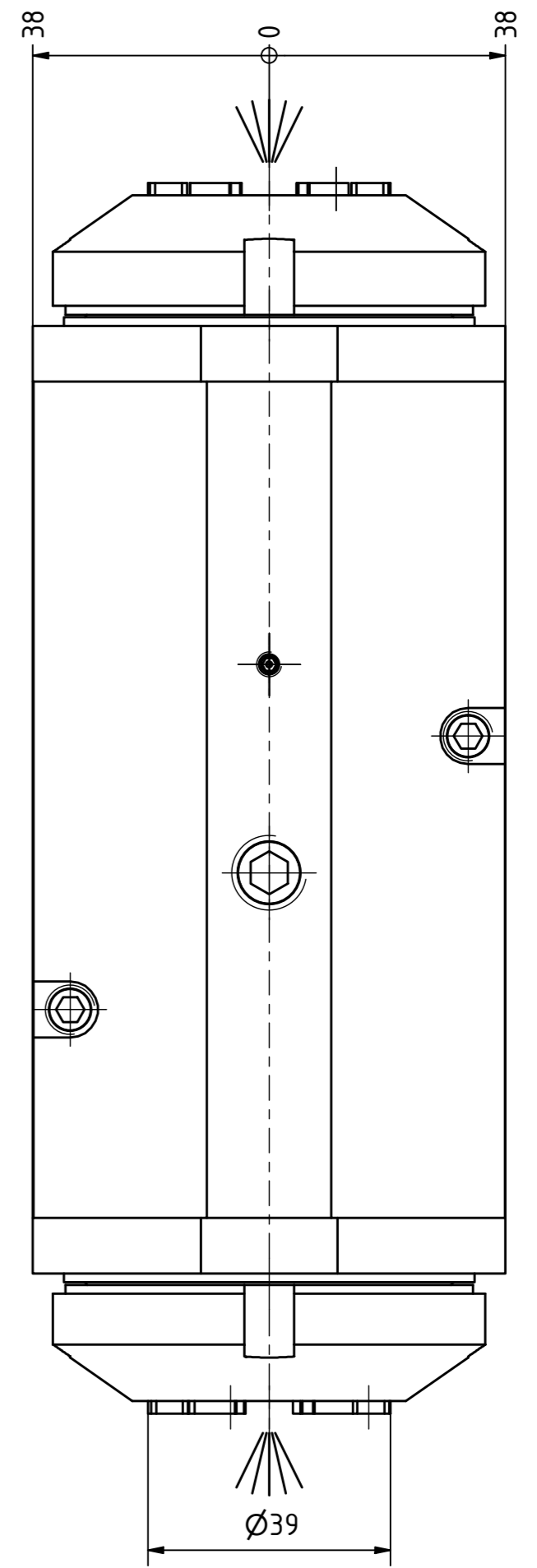
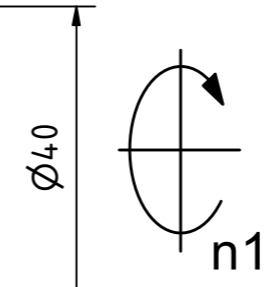

Spannzange / collet ER32 DIN6499
Spannbereich / clamping range: 2,0 - 20,0

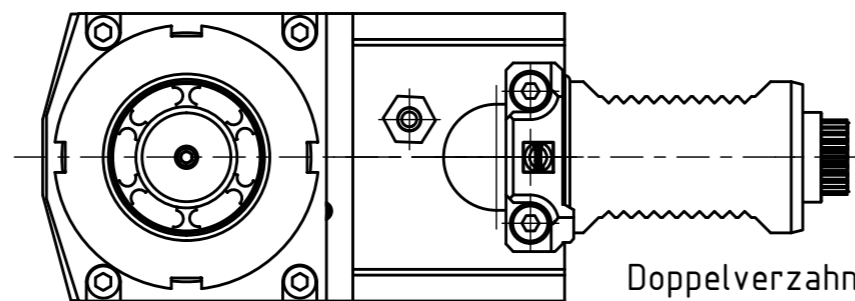
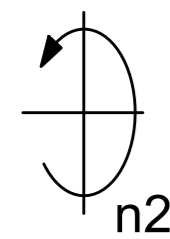

Doppelverzahnung Lizenz Traub
double tooth system licence Traub

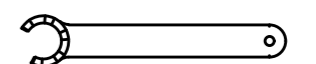
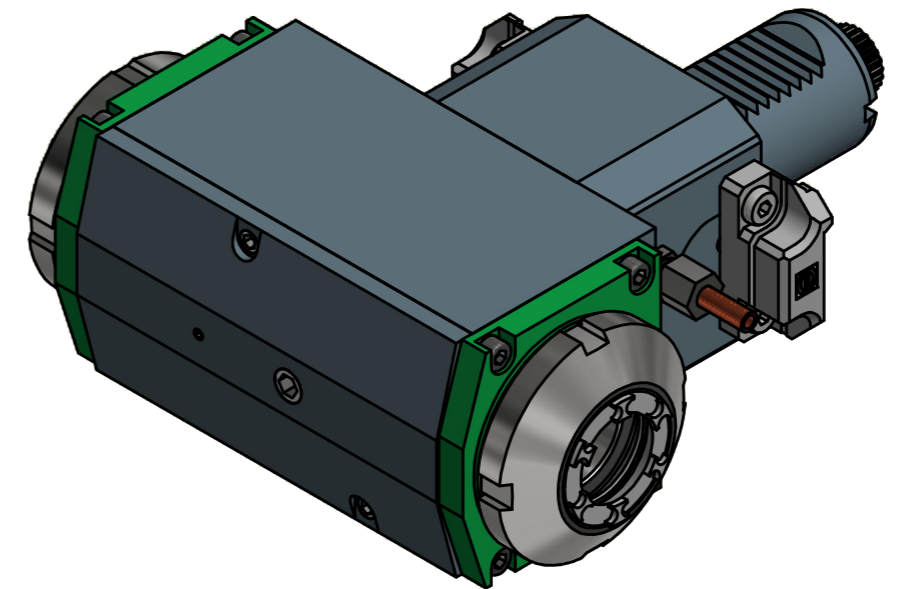

Spannzangenschlüssel für innenliegende Mutter
Clamping wrench for internal collet
232AX

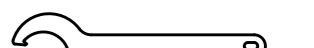

Hakenschlüssel mit Nase
Hook wrench with nose end
DIN1810 A 68x75

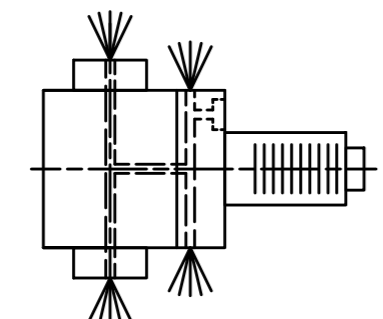



Innen- und Aussenkuehlung / Inside and outside coolant supply
Kuehlmittelfiltrierung=50µ / coolant filtration=50µ

Copyright EWS Tool Technologies
Weitergabe und Vervielfaeltigung dieser Unterlage, Verwertung und Mitteilung ihres Inhalts nicht gestattet, soweit nicht ausdrecklich zugestanden. Zuwiderhandlungen verpflichten zu Schadenersatz.

Bemerkung - Note Für Trockenlauf geeignet! Use without coolant fluid allowed!	Technische Daten - technical data Weight = 9.501 [kg]
	Torque max. (M1/M2) = 50 / 50 50 [Nm]
	Speed max. (n1/n2) = 6000 / 6000 6000 [1/min]
	Gear ratio (i)=n1:n2 = 1:1 1:1
	Pressure (pmax) = 70 [bar]

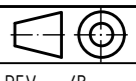
Benennung - Title Radial Bohr und Fräskopf Radial drilling and milling head

 EWS Weigle GmbH & Co. KG Maybachstr. 1 D-73066 Ulm/ingen www.ews-tools.de	Technische Aenderungen vorbehalten! Subject to technical modifications! IDENT: DEWS125003	 MNR REV: -/B	
Nr. - No. 60.4032DCTXRLIKDTRIM	MNR 220102		