



Ceramic Seal



Highspeed



Tech Details

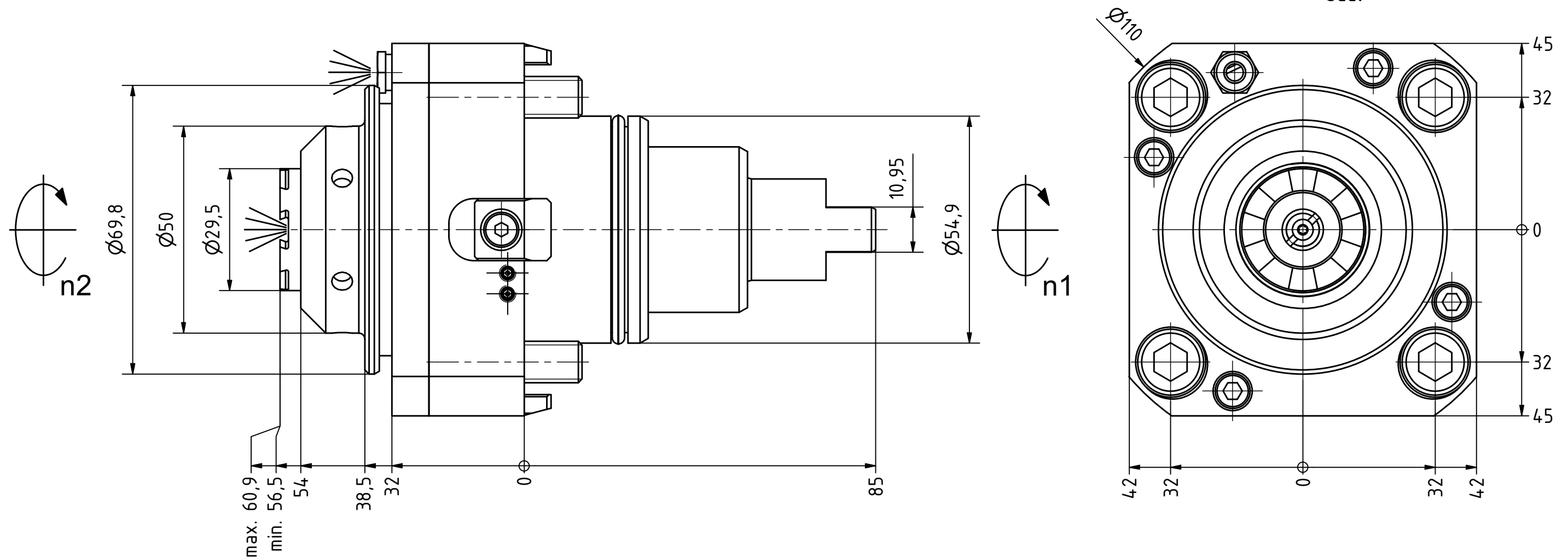

Spannzange / collet ER25 DIN6499
 Spannungsbereich / clamping range: 1,0 - 16,0

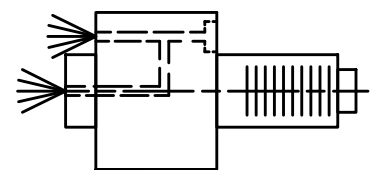

Innen- und Aussenkuehlung / Inside and outside coolant supply
 Kuehlmittelfiltrierung < 50µ / coolant filtration < 50µ

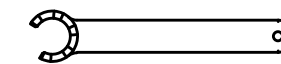
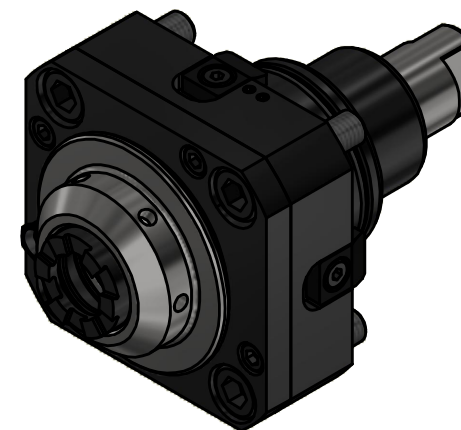

Spannzangenschlüssel für innenliegende Mutter
 Clamping wrench for internal collet
 225AX

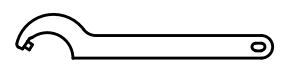

Hakenschlüssel mit Zapfen
 Hook wrench with fixed pin
 DIN1810 B 45x50

Copyright **EWS Tool Technologies**
 Weitergabe und Vervielfaeltigung dieser Unterlage, Verwertung und Mitteilung ihres Inhalts nicht gestattet, soweit nicht ausdrecklich zugestanden. Zuwiderhandlungen verpflichten zu Schadenersatz.

Bemerkung - Note
 Für Trockenlauf geeignet!
 Use without coolant fluid allowed!

Technische Daten - technical data
 Weight = 2.754 [kg]
 Torque max. (M1/M2) = 50 / 50 [Nm]
 Speed max. (n1/n2) = 10000 / 10000 [1/min]
 Gear ratio (i)=n1:n2 = 1:1
 Pressure (pmax) = 70 [bar]

Benennung - Title
Axial Bohr und Fräskopf
Axial drilling and milling head

EWS Tool Technologies
 EWS Weigele GmbH & Co. KG
 Maybachstr. 1
 D-73066 UHINGEN
 www.ews-tools.de

Technische Aenderungen vorbehalten!
 Subject to technical modifications!
 IDENT: DEWS233626
 Nr. - No. 40.5525VLHP2IKCIMHSD10-RF

REV: -/D
 MNR. 217088

