

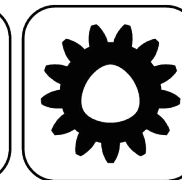

Ceramic Seal



Butterfly Seal



Polygon Joint

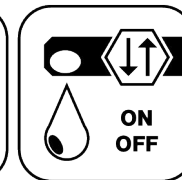

Coolant Management



Tech Details

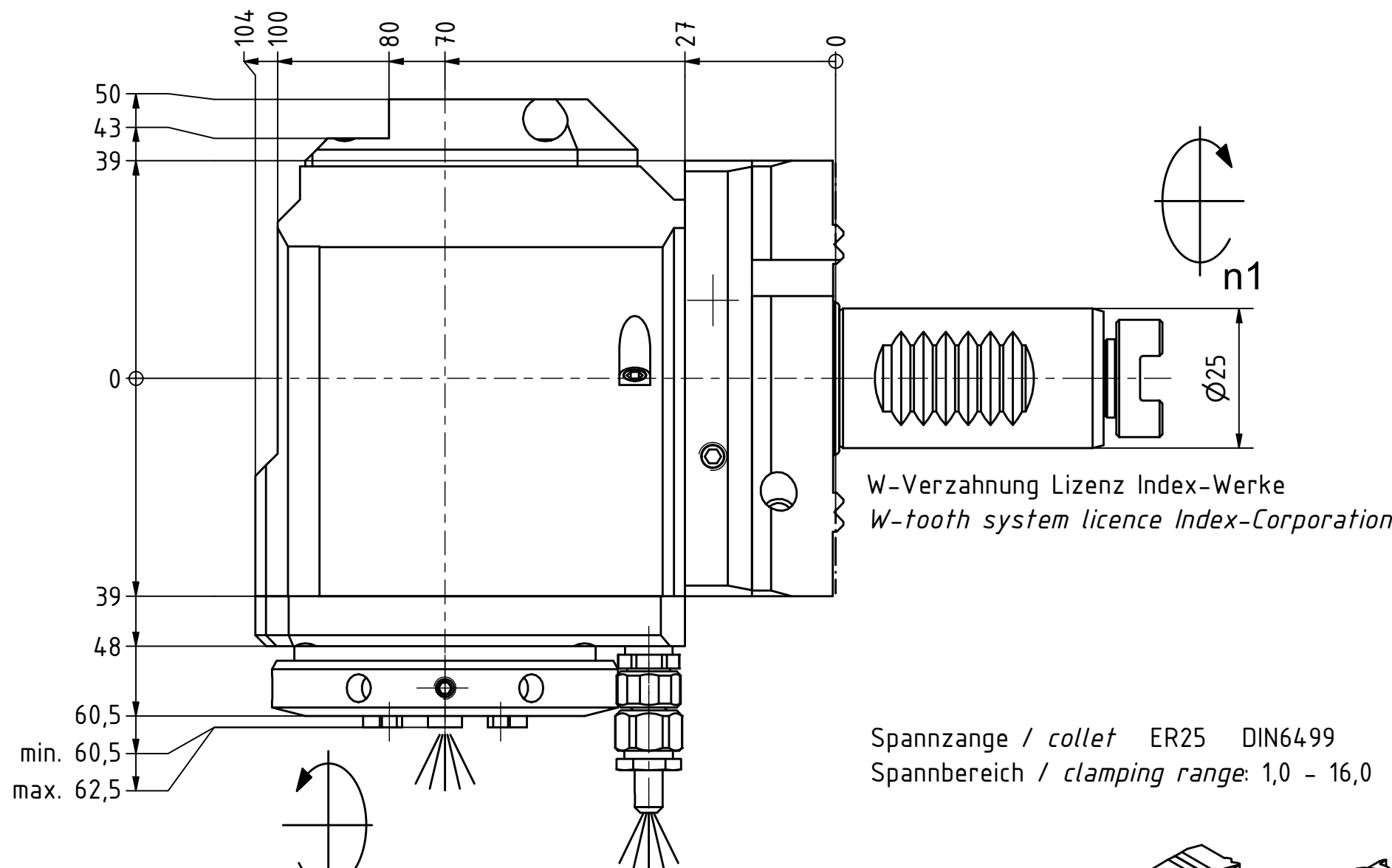

Spannzange / collet ER25 DIN6499  
 Spannbereich / clamping range: 1,0 - 16,0

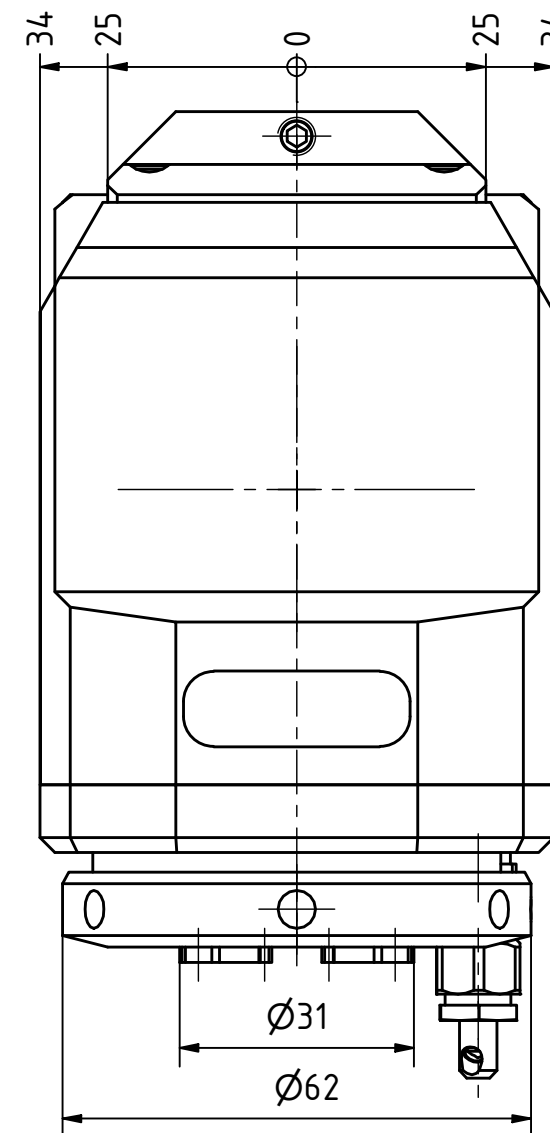

Spannzangenschlüssel für innenliegende Mutter  
 Clamping wrench for internal collet  
 225AX

Hakenschlüssel mit Zapfen  
 Hook wrench with fixed pin  
 DIN1810 B 58x62

Copyright **EWS Tool Technologies**  
 Weitergabe und Vervielfaeltigung dieser Unterlage, Verwertung und Mitteilung ihres Inhalts nicht gestattet, soweit nicht ausdrecklich zugestanden. Zuwiderhandlungen verpflichten zu Schadenersatz.

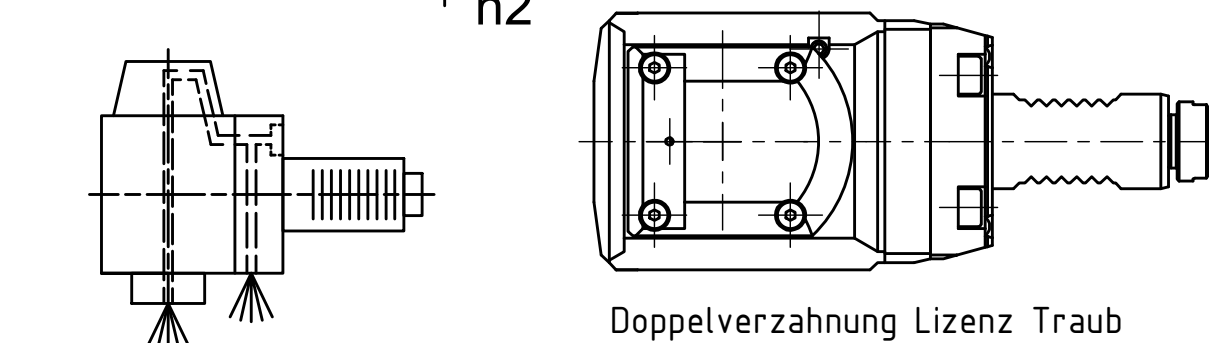

Doppelverzahnung Lizenz Traub  
 double tooth system licence Traub

Innen- und Aussenkuehlung / Inside and outside coolant supply  
 Kuehlmittelfiltrierung <math>< 50\mu</math> / coolant filtration <math>< 50\mu</math>

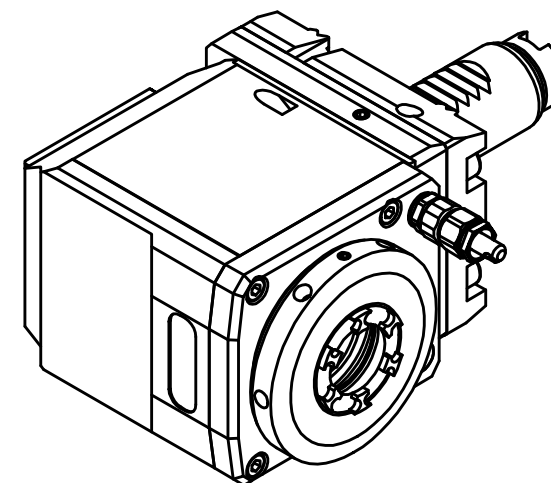

Bemerkung - Note  
 Für Trockenlauf geeignet!  
 Use without coolant fluid allowed!

Technische Daten - technical data  
 Weight = 3.974 [kg]  
 Torque max. (M1/M2) = 25 / 25 [Nm]  
 Speed max. (n1/n2) = 8000 / 8000 [1/min]  
 Gear ratio (i)=n1:n2 = 1:1  
 Pressure (pmax) = 70 [bar]

Benennung - Title  
**Radial Bohr und Fräskopf**  
**Radial drilling and milling head**



Nr. - No.  
**60.2525G200RLIKDWIM#01**

Technische Aenderungen vorbehalten!  
 Subject to technical modifications!  
 IDENT: DEWS143818

REV: -/B  
 MNR.  
**220035**

