

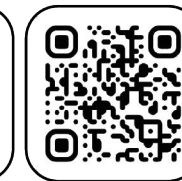

Ceramic Seal

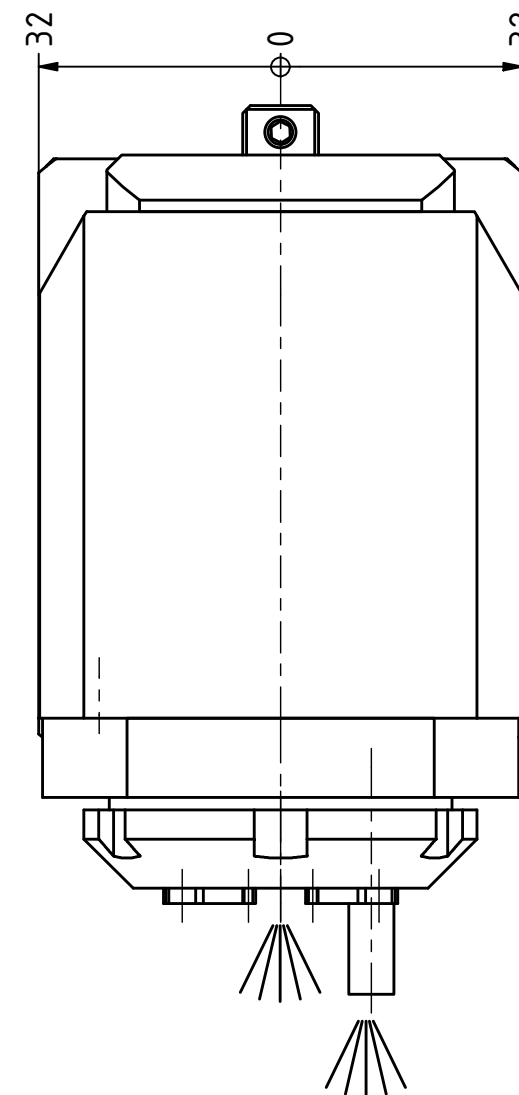

Tech Details

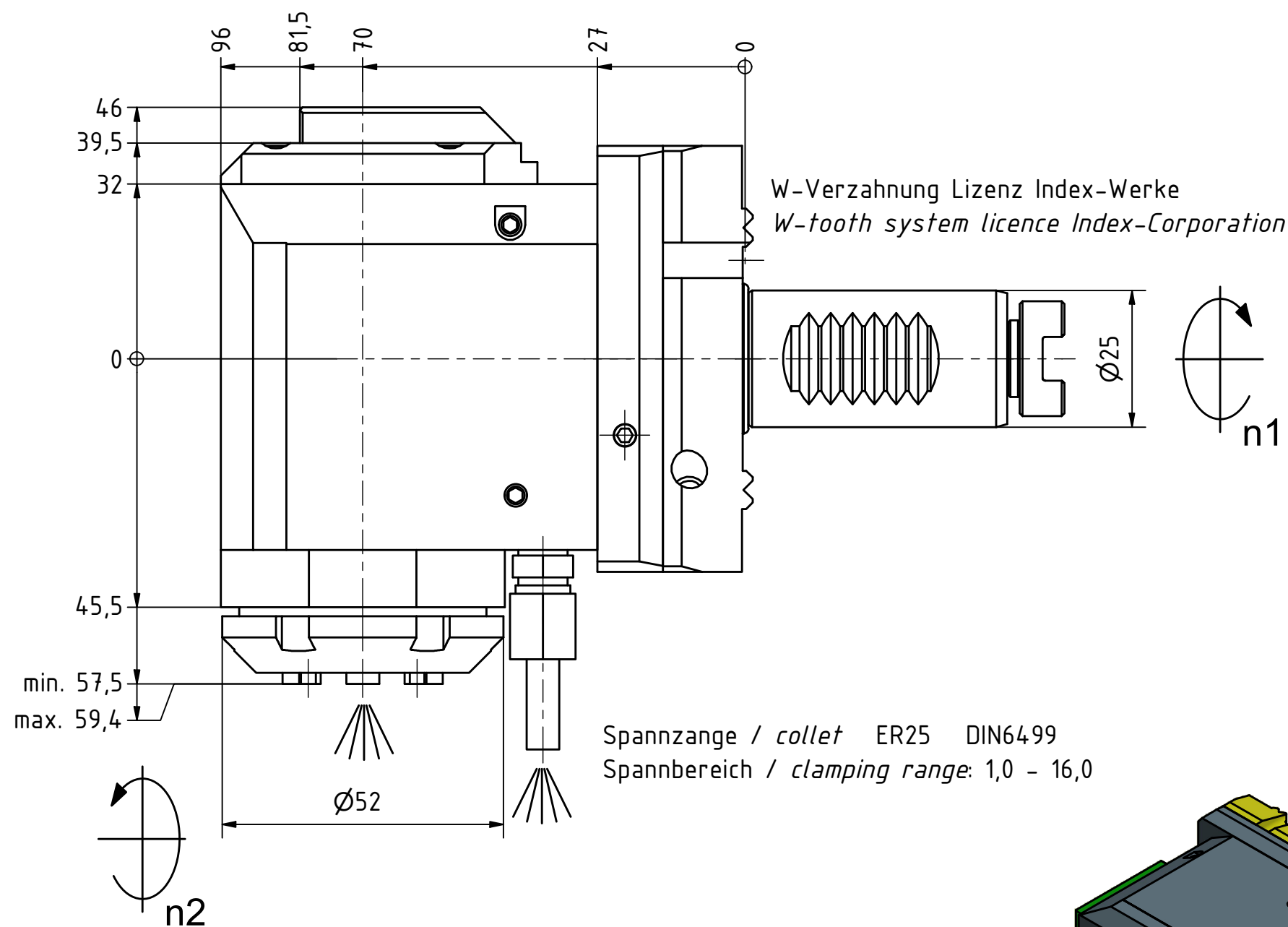

 Spannzangenschlüssel für innenliegende Mutter
Clamping wrench for internal collet
225AX

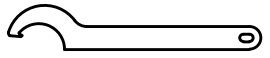
 Hakenschlüssel mit Nase
Hook wrench with nose end
DIN1810 A 52x55

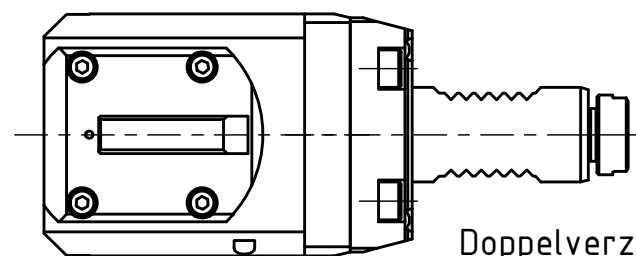
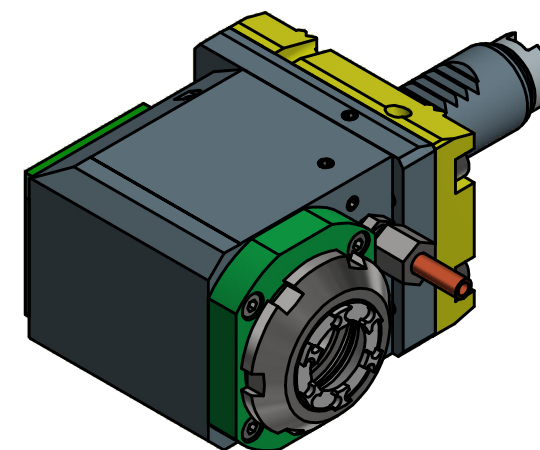

Doppelverzahnung Lizenz Traub
double tooth system licence Traub

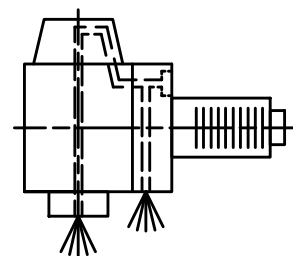

Innen- und Aussenkuehlung / Inside and outside coolant supply
Kuehlmittelfiltrierung-50 μ / coolant filtration-50 μ

Copyright **EWS Tool Technologies**
Weitergabe und Vervielfaeltigung dieser Unterlage,
Verwertung und Mitteilung ihres Inhalts nicht
gestattet, soweit nicht ausdrecklich zugestanden.
Zuwiderhandlungen verpflichten zu Schadenersatz.

Bemerkung - Note
Für Trockenlauf geeignet!
Use without coolant fluid allowed!

Technische Daten - technical data
Weight = 3,361 [kg]
Torque max. (M1/M2) = 25 / 25 [Nm]
Speed max. (n1/n2) = 8000 / 8000 [1/min]
Gear ratio (i)=n1:n2 = 1:1
Pressure (pmax) = 70 [bar]

Benennung - Title
Radial Bohr und Fräskopf
Radial drilling and milling head



Nr. - No.
60.2525G200RLIKDWIM

Technische Aenderungen vorbehalten!
Subject to technical modifications!
IDENT: DEWS104995



REV: -/A

MNR.
219552

