

Spannzange / collet ER25 DIN6499  
Spannbereich / clamping range: 1,0 - 16,0

Gewindebohrzange / tapping collet  
ET-1-25 M3-M12

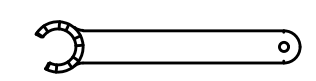

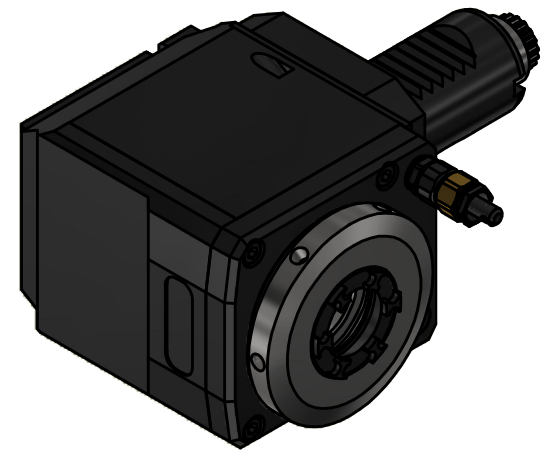
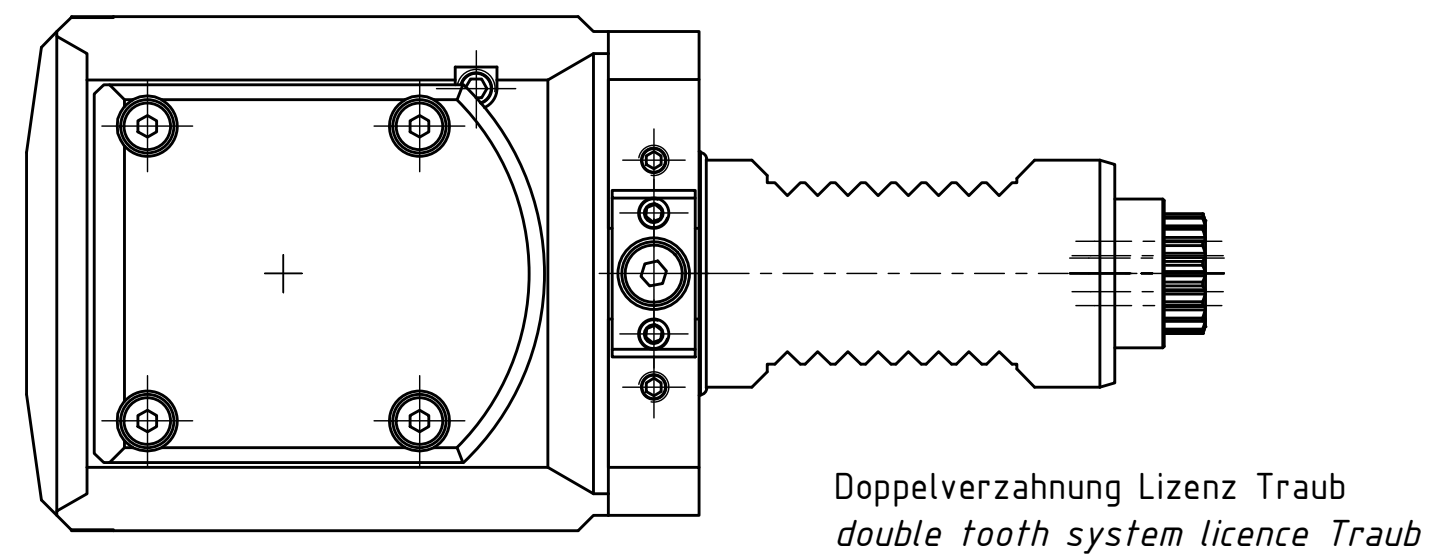
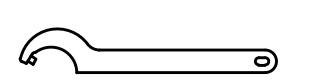

Spannzangenschlüssel für  
innenliegende Mutter  
Clamping wrench for  
internal collet  
225AX



Hakenschlüssel  
mit Zapfen  
Hook wrench  
with fixed pin  
DIN1810 B 58x62

Copyright **EWS Tool Technologies**  
Weitergabe und Vervielfältigung dieser Unterlage,  
Verwertung und Mitteilung ihres Inhalts nicht  
gestattet, soweit nicht ausdrücklich zugestanden.  
Zuwerhandlungen verpflichten zu Schadenersatz.

Bemerkung - Note	Technische Daten - technical data Weight = 3.392 [kg] Torque max. (M1/M2) = 32 / 32 [Nm] Speed max. (n1/n2) = 8000 / 8000 [1/min] Gear ratio (i)=n1:n2 = 1:1	Benennung - Title <b>Radial Bohr und Fräskopf</b> <i>Radial drilling and milling head</i>	 EWS Weigle GmbH & Co. KG Maybachstr. 1 D-73066 Uhlingen www.ews-tools.de Nr. - No. <b>60.3025CTXRLIM#01</b>	Technische Änderungen vorbehalten! Subject to technical modifications! IDENT: DEWS229024 MNR. REV: -/E <b>219364</b>	
------------------	--	---	--	---	---