

Spannzange / collet ER25 DIN6499  
 Spannbereich / clamping range: 1,0 - 16,0

Gewindebohrzange / tapping collet  
 ET-1-25 M3-M12

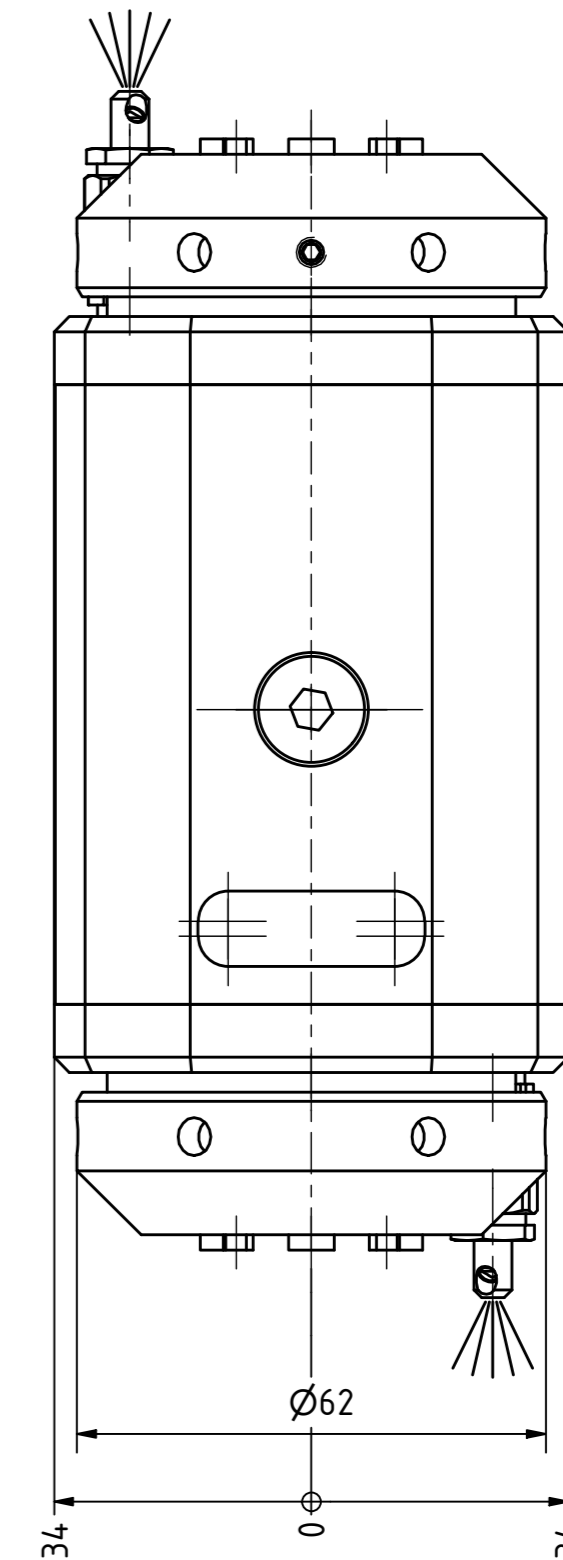
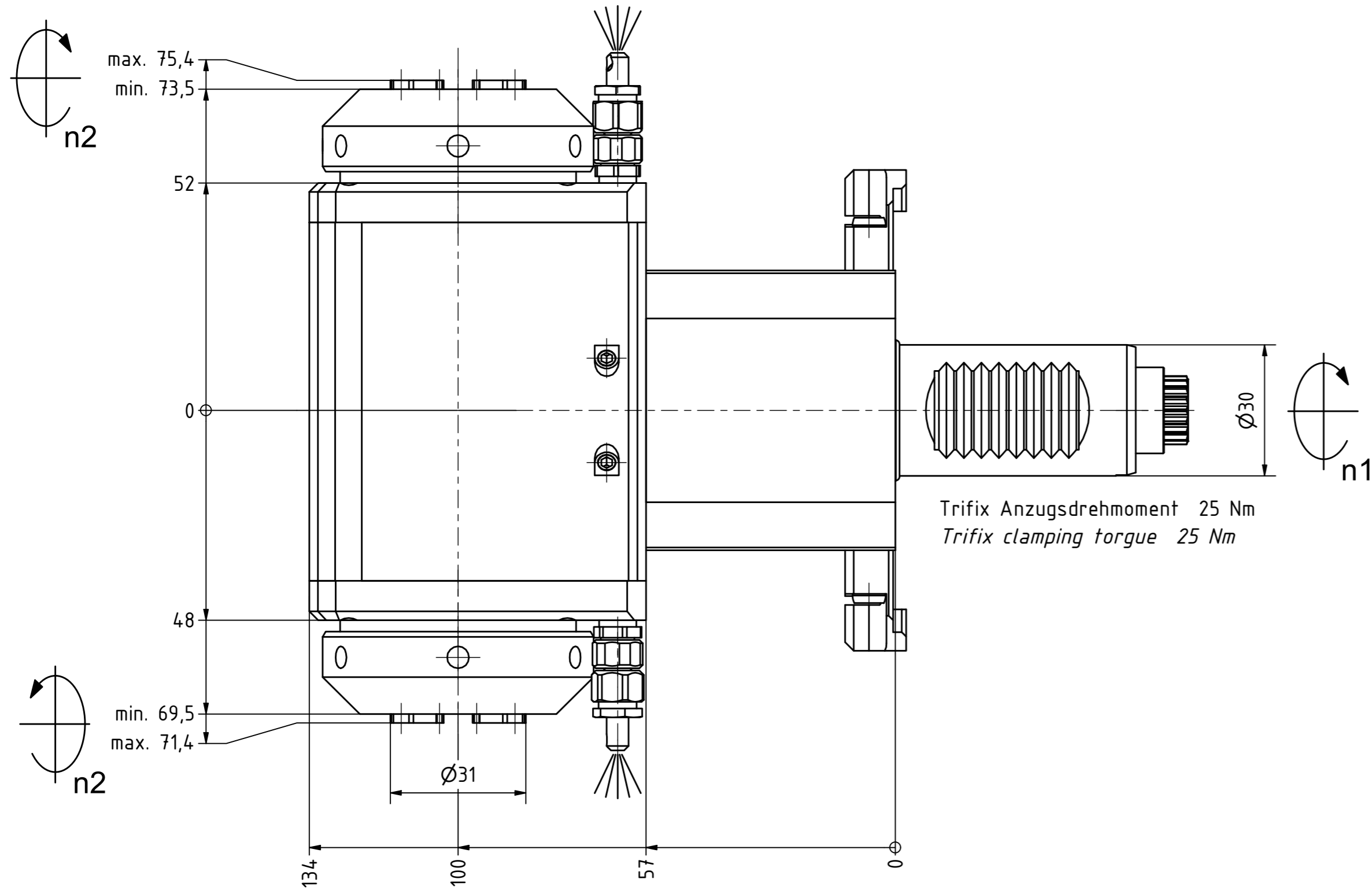
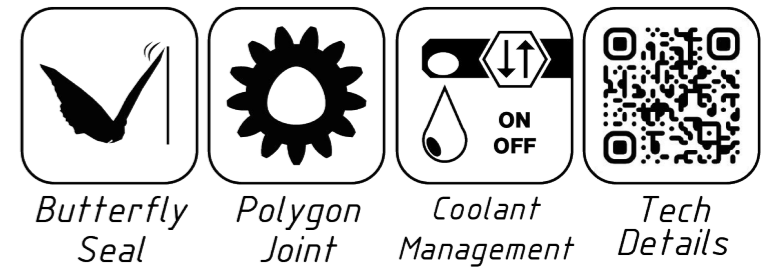

Spannzange / collet ER25 DIN6499  
 Spannbereich / clamping range: 1,0 - 16,0

Gewindebohrzange / tapping collet  
 ET-1-25 M3-M12

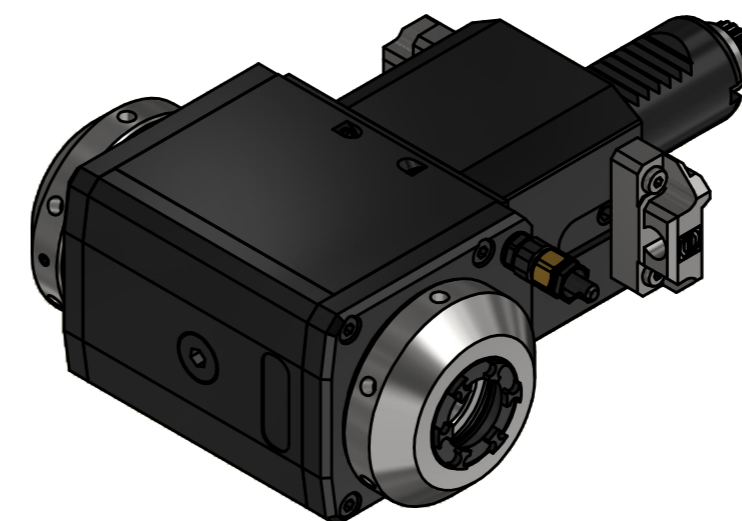
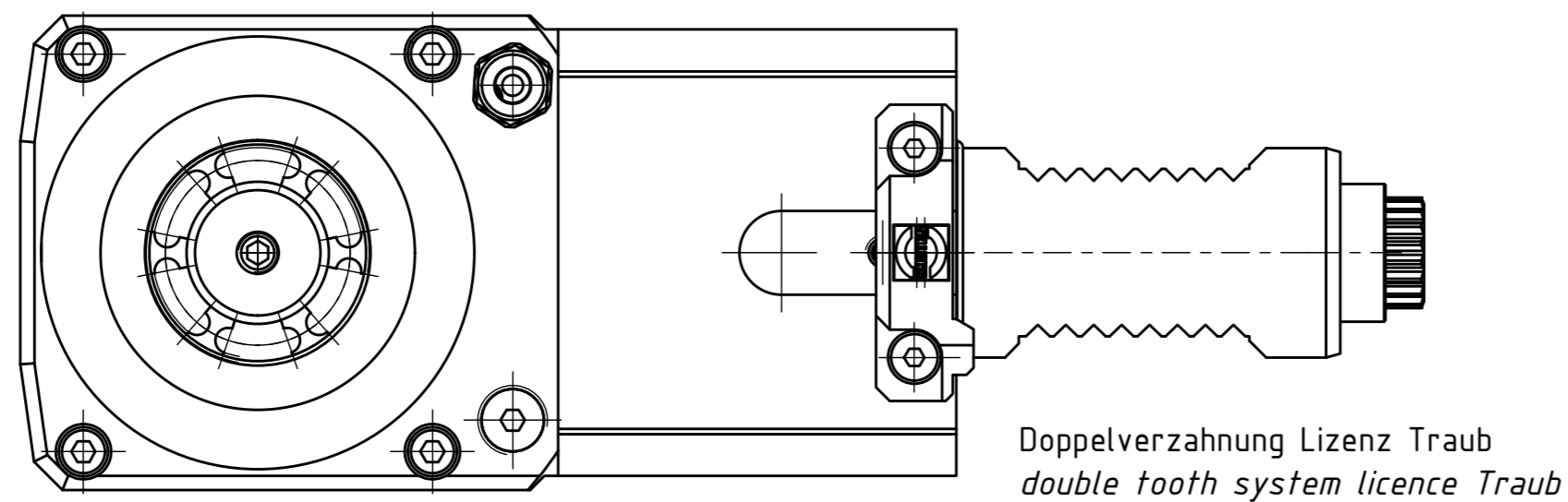

Spannzangenschlüssel für  
 innenliegende Mutter  
 Clamping wrench for  
 internal collet  
 225AX

Hakenschlüssel  
 mit Zapfen  
 Hook wrench  
 with fixed pin  
 DIN1810 B 58x62

Copyright EWS Tool Technologies  
 Weitergabe und Vervielfältigung dieser Unterlage,  
 Verwertung und Mitteilung ihres Inhalts nicht  
 gestattet, soweit nicht ausdrücklich zugestanden.  
 Zuwiderhandlungen verpflichten zu Schadenersatz.

Bemerkung - Note	Technische Daten - technical data Weight = 5,865 [kg] Torque max. (M1/M2) = 32 / 32   32 [Nm] Speed max. (n1/n2) = 8000 / 8000   8000 [1/min] Gear ratio (i)=n1:n2 = 1:1   1:1	Benennung - Title <b>Radial Bohr und Fräskopf</b> <b>Radial drilling and milling head</b>	<table border="1"> <tr> <td data-bbox="2226 1915 2463 1974"> <b>EWS</b>                      EWS Weigle GmbH &amp; Co. KG                      Maybachstr. 1                      D-73066 Ulm/ingen                      www.ews-tools.de                 </td> <td data-bbox="2463 1915 2671 1974">                     Technische Änderungen vorbehalten!                      Subject to technical modifications!                      IDENT: DEWS229563                 </td> <td data-bbox="2671 1915 2908 1974">                       REV: -/D                      MNR.                 </td> </tr> <tr> <td data-bbox="2226 1974 2463 2043">                     Nr. - No.  <b>60.3025LDCTXRLTFIM</b> </td> <td data-bbox="2463 1974 2671 2043">                     218667                 </td> <td data-bbox="2671 1974 2908 2043"> <b>QR</b> </td> </tr> </table>	<b>EWS</b> EWS Weigle GmbH & Co. KG Maybachstr. 1 D-73066 Ulm/ingen www.ews-tools.de	Technische Änderungen vorbehalten! Subject to technical modifications! IDENT: DEWS229563	 REV: -/D MNR.	Nr. - No. <b>60.3025LDCTXRLTFIM</b>	218667	<b>QR</b>
<b>EWS</b> EWS Weigle GmbH & Co. KG Maybachstr. 1 D-73066 Ulm/ingen www.ews-tools.de	Technische Änderungen vorbehalten! Subject to technical modifications! IDENT: DEWS229563	 REV: -/D MNR.							
Nr. - No. <b>60.3025LDCTXRLTFIM</b>	218667	<b>QR</b>							