

Ceramic Seal Butterfly Seal Polygon Joint Coolant Management Tech Details

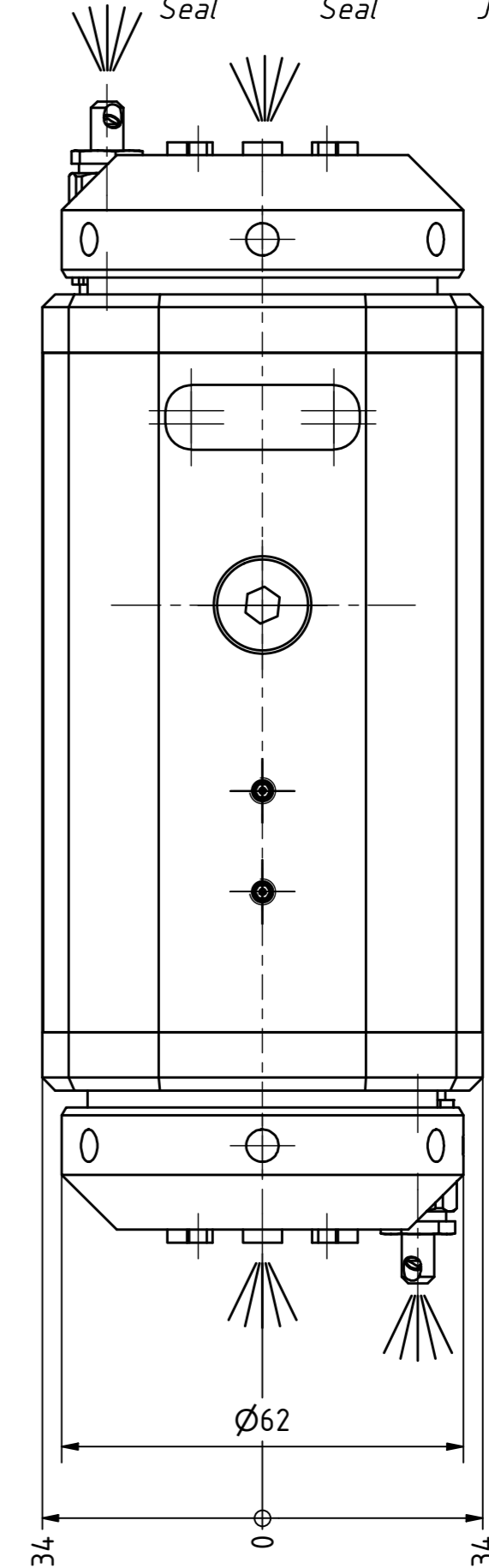

Spannzange / collet ER25 DIN6499  
Spannbereich / clamping range: 1,0 - 16,0

Trifix Anzugsdrehmoment 25 Nm  
Trifix clamping torque 25 Nm

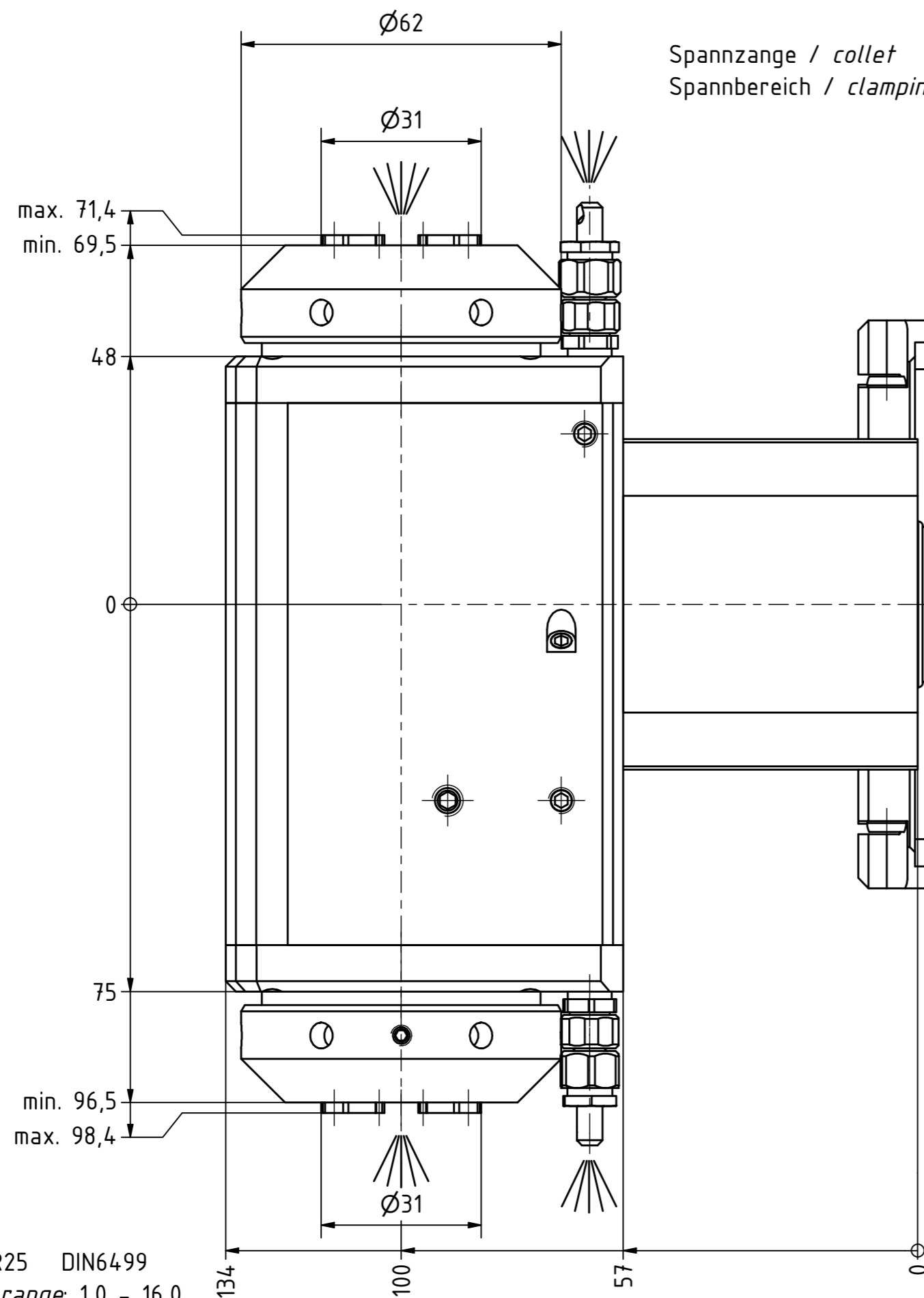

Spannzange / collet ER25 DIN6499  
Spannbereich / clamping range: 1,0 - 16,0

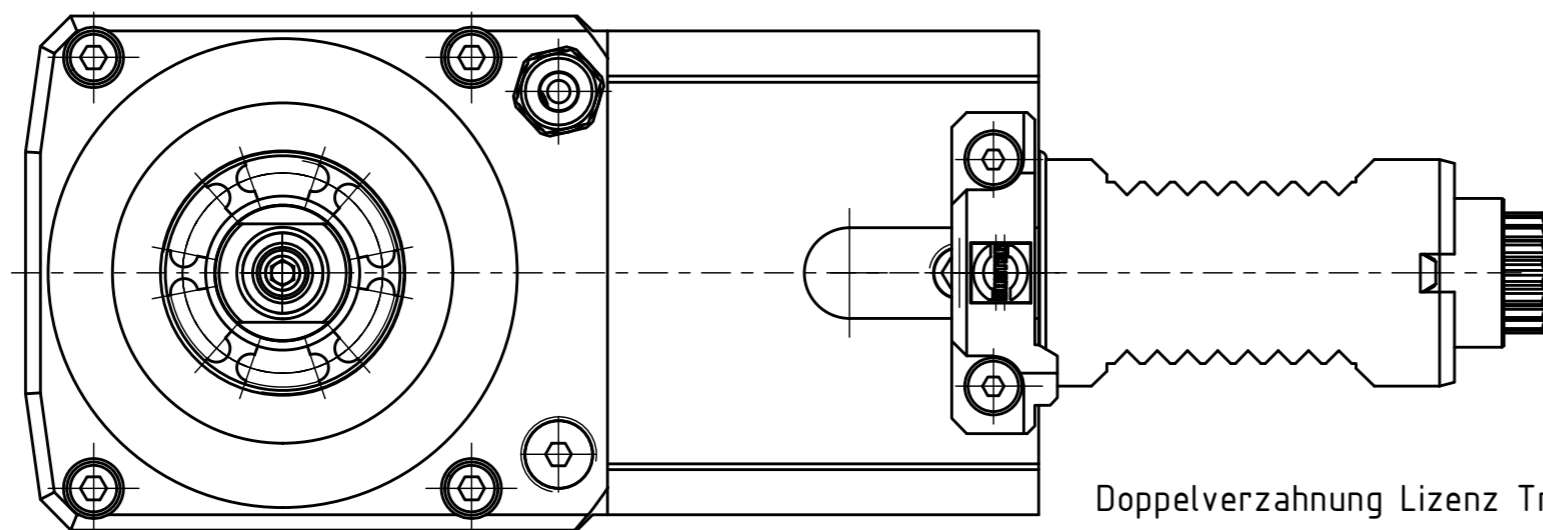

Doppelverzahnung Lizenz Traub  
double tooth system licence Traub

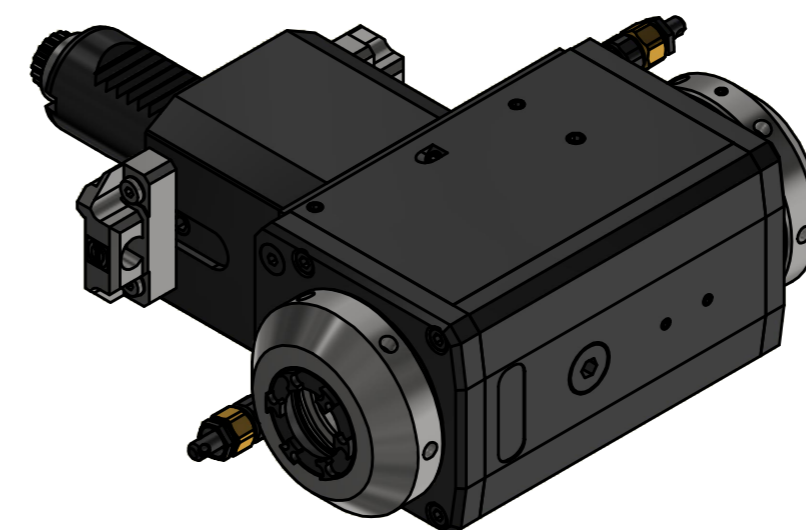

Spannzangenschlüssel für innenliegende Mutter  
Clamping wrench for internal collet  
225AX

Hakenschlüssel mit Zapfen  
Hook wrench with fixed pin  
DIN1810 B 58x62

Copyright EWS Tool Technologies  
Weitergabe und Vervielfältigung dieser Unterlage, Verwertung und Mitteilung ihres Inhalts nicht gestattet, soweit nicht ausdrücklich zugestanden. Zuwiderhandlungen verpflichten zu Schadenersatz.

Innen- und Aussenkühlung / Inside and outside coolant supply  
Kühlmittelfiltrierung=50µ / coolant filtration=50µ

Bemerkung - Note  
Für Trockenlauf geeignet!  
Use without coolant fluid allowed!

Technische Daten - technical data  
Weight = 6.848 [kg]  
Torque max. (M1/M2) = 32 / 32 | 32 [Nm]  
Speed max. (n1/n2) = 8000 / 8000 | 8000 [1/min]  
Gear ratio (i)=n1:n2 = 1:1 | 1:1  
Pressure (pmax) = 70 [bar]

Benennung - Title  
Radial Bohr und Fräskopf  
Radial drilling and milling head

	<small>EWS Weigle GmbH &amp; Co. KG Maybachstr. 1 D-73066 Ulm/ingen www.ews-tool.de</small>	<small>Technische Änderungen vorbehalten! Subject to technical modifications!</small>	
		<small>IDENT: DEWS270599</small>	
<small>Nr. - No.</small> 60.3025LDCTXRLIKCTFLIM	<small>MNR.</small> 218665	<b>QR</b>	