

Spannzange / collet ER25 DIN6499
 Spannbereich / clamping range: 1,0 - 16,0

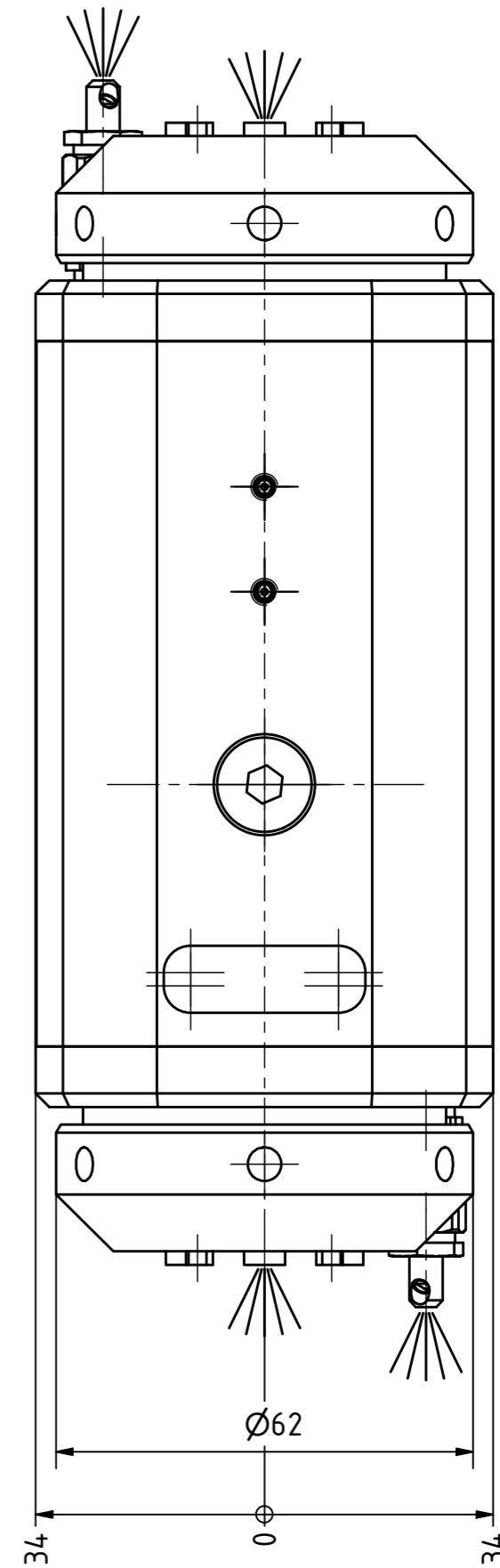

Spannzange / collet ER25 DIN6499
 Spannbereich / clamping range: 1,0 - 16,0

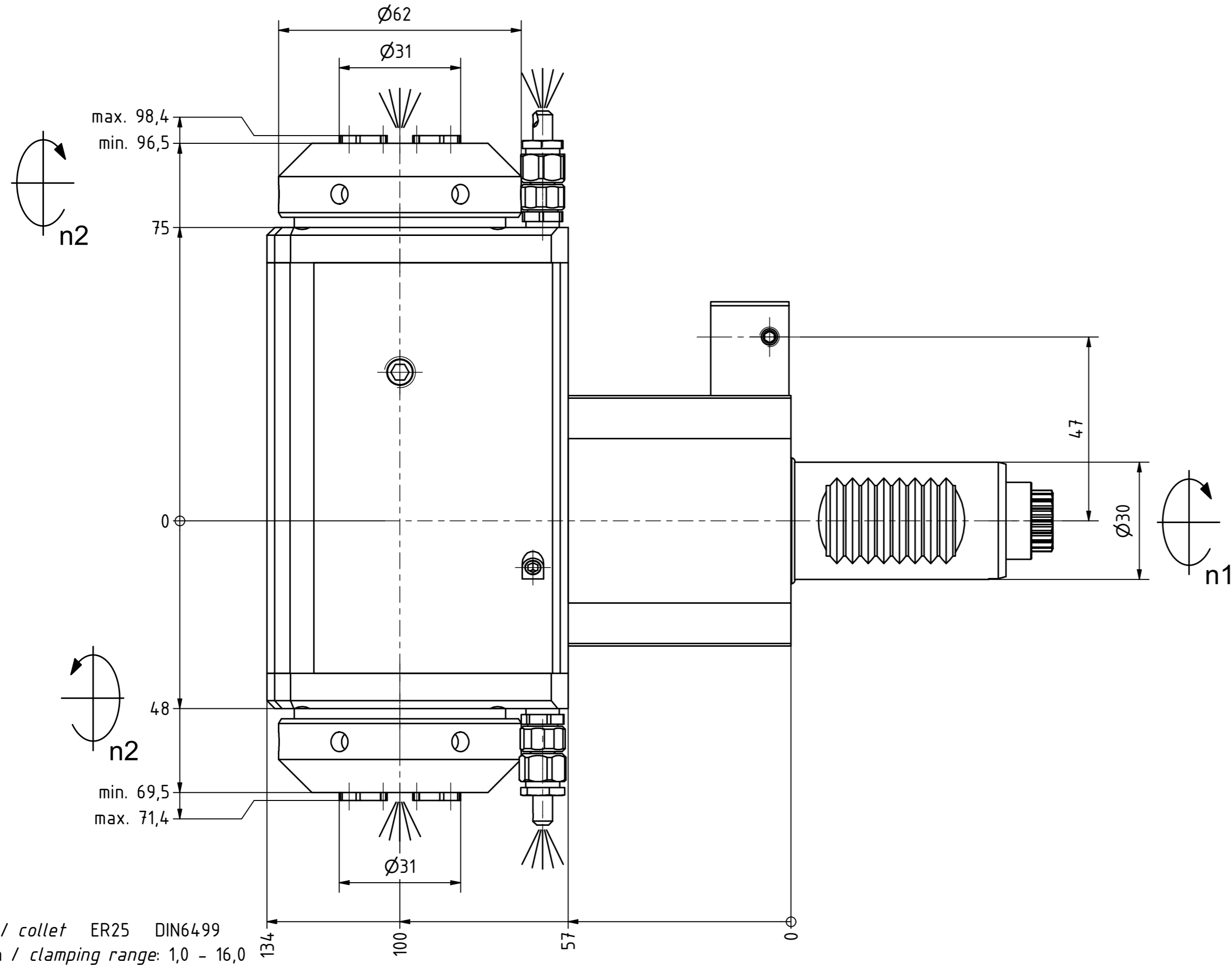
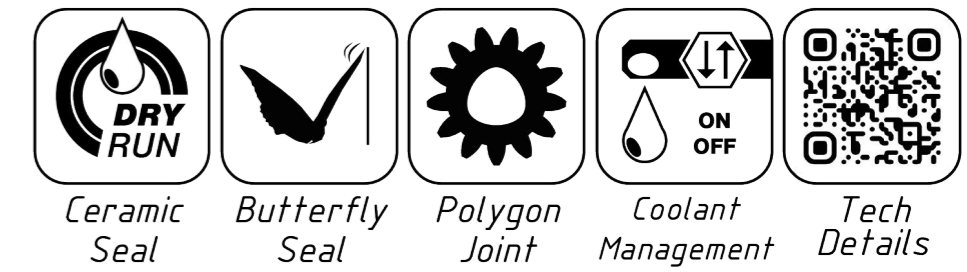
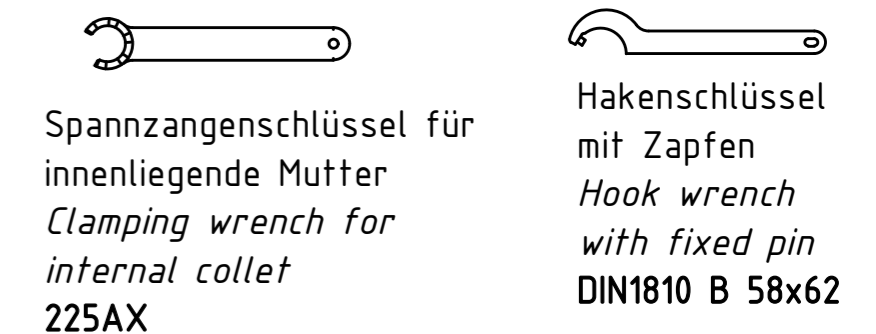
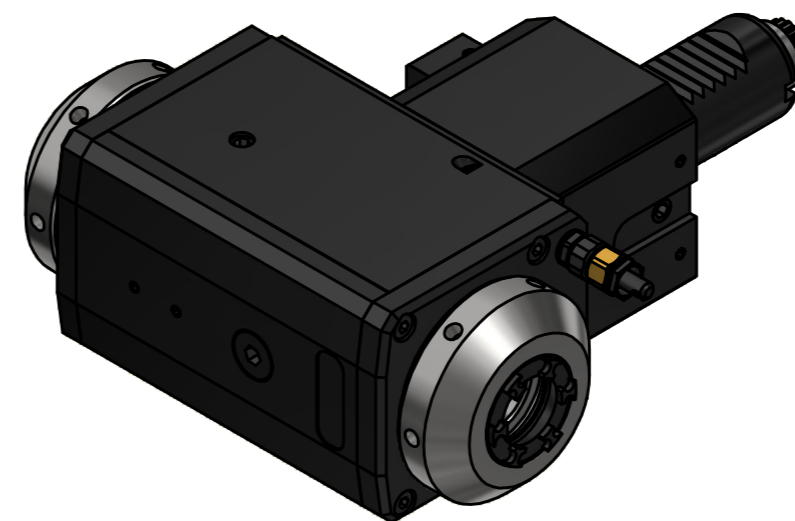
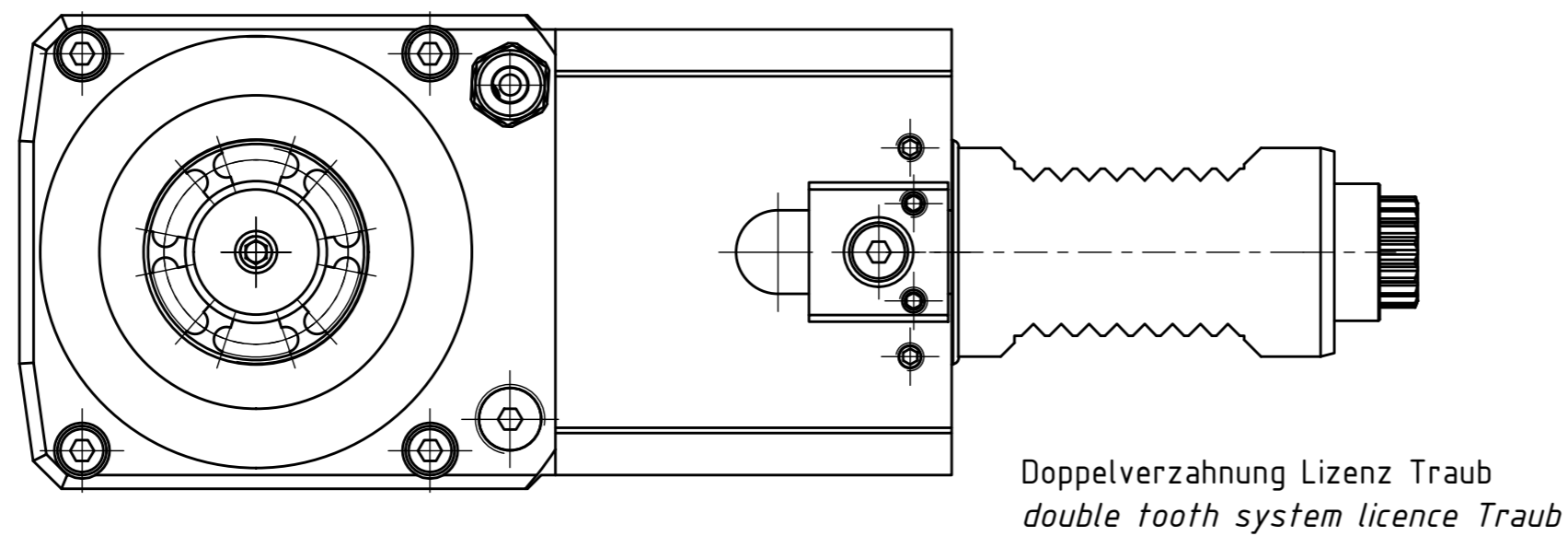

Copyright EWS Tool Technologies
 Weitergabe und Vervielfältigung dieser Unterlage, Verwertung und Mitteilung ihres Inhalts nicht gestattet, soweit nicht ausdrücklich zugestanden. Zuwiderhandlungen verpflichten zu Schadenersatz.

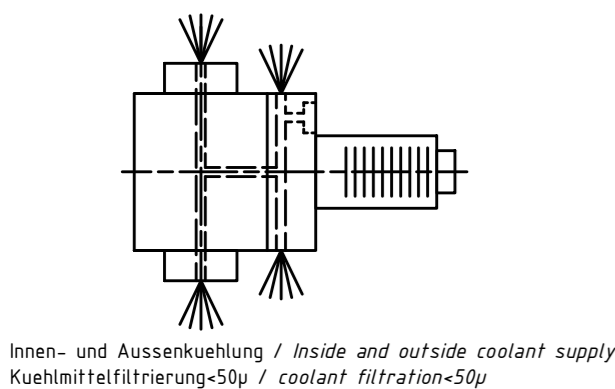

Bemerkung - Note
 Für Trockenlauf geeignet!
 Use without coolant fluid allowed!

Technische Daten - technical data
 Weight = 6.729 [kg]
 Torque max. (M1/M2) = 32 / 32 | 32 [Nm]
 Speed max. (n1/n2) = 8000 / 8000 | 8000 [1/min]
 Gear ratio (i)=n1:n2 = 1:1 | 1:1
 Pressure (pmax) = 70 [bar]

Benennung - Title
Radial Bohr und Fräskopf
Radial drilling and milling head

EWS Weigle GmbH & Co. KG Maybachstr. 1 D-73066 Ulm/ingen www.ews-tool.de	Technische Änderungen vorbehalten! Subject to technical modifications! IDENT: DEWS229621	REV: -/C MNR. 218664	QR
	Nr. - No. 60.3025LDCTXRLIKCIM		