

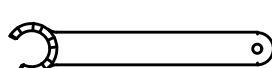

 Hakenschlüssel
 mit Nase
*Hook wrench with
 nose end*
DIN1810 A 58x62

 Spannzangenschlüssel für
 innenliegende Mutter
*Clamping wrench for
 internal collet*
225AX

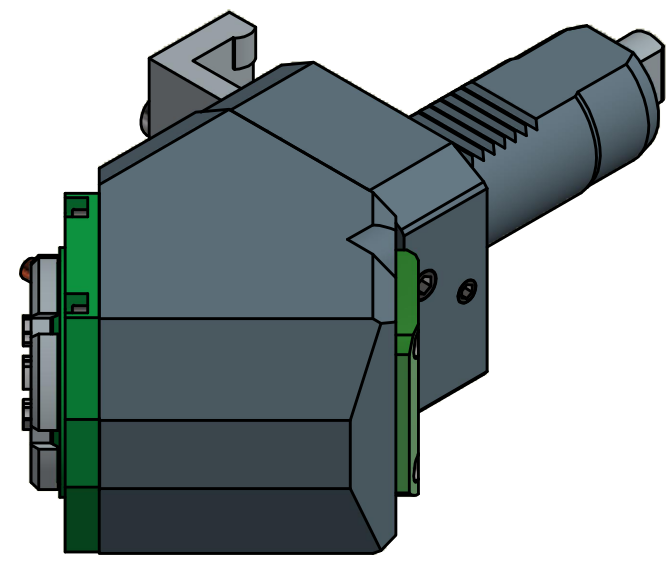

Copyright **EWS Tool Technologies**
 Weitergabe und Vervielfaeltigung dieser Unterlage,
 Verwertung und Mitteilung ihres Inhalts nicht
 gestattet, soweit nicht ausdrecklich zugestanden.
 Zuwiderhandlungen verpflichten zu Schadenersatz.

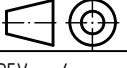
Bemerkung - Note	Technische Daten - technical data Weight = 6.076 [kg] Torque max. (M1/M2) = 50 / 50 [Nm] Speed max. (n1/n2) = 6000 / 6000 [1/min] Gear ratio (i)=n1:n2 = 1:1	Benennung - Title Radial Bohr und Fräskopf <i>Radial drilling and milling head</i>	 EWS Weigle GmbH & Co. KG Maybachstr. 1 D-73066 UHINGEN www.ews-tools.de	Technische Aenderungen vorbehalten! <i>Subject to technical modifications!</i> IDENT: D-EWS-119364 MNR. 159355	 REV: -/- 
------------------	--	---	--	---	--