

Doppelverzahnung Lizenz Traub  
double tooth system licence Traub

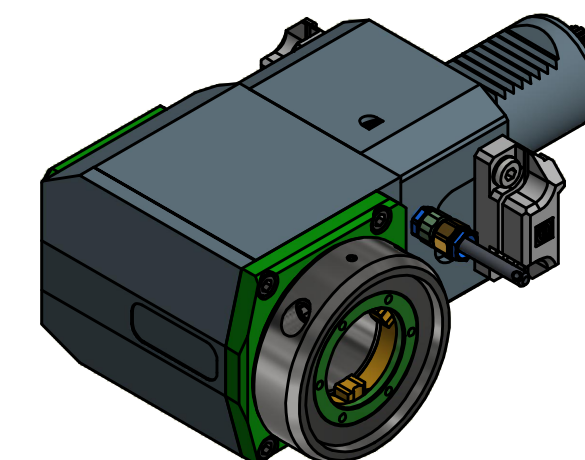

Copyright **EWS Tool Technologies**  
Weitergabe und Vervielfältigung dieser Unterlage,  
Verwertung und Mitteilung ihres Inhalts nicht  
gestattet, soweit nicht ausdrücklich zugestanden.  
Zuwerhandlungen verpflichten zu Schadenersatz.

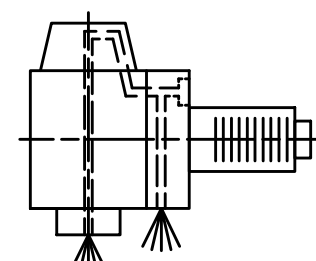

Innen- und Aussenkuehlung / Inside and outside coolant supply  
Kuehlmittelfiltrierung=50µ / coolant filtration=50µ

<p>Bemerkung - Note Für Trockenlauf geeignet! Use without coolant fluid allowed!</p>	<p>Technische Daten - technical data Weight = 6.892 [kg] Torque max. (M1/M2) = 63 / 63 [Nm] Speed max. (n1/n2) = 6000 / 6000 [1/min] Gear ratio (i)=n1:n2 = 1:1 Pressure (pmax) = 70 [bar]</p>	<p>Benennung - Title <b>Radial Bohr und Fräskopf</b> <b>Radial drilling and milling head</b></p>	<p><b>EWS</b> Tool Technologies EWS Weigle GmbH &amp; Co. KG Maybachstr. 1 D-73066 Uhlingen www.ews-tools.de</p>	<p>Technische Änderungen vorbehalten! Subject to technical modifications! IDENT: DEWS137268 REV: -/C MNR.</p>	<p><b>QR</b> 215775</p>
--	--	--	--	---	-----------------------------