

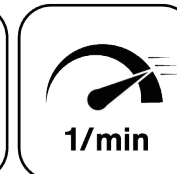

Ceramic Seal



Butterfly Seal



Highspeed



Tech Details

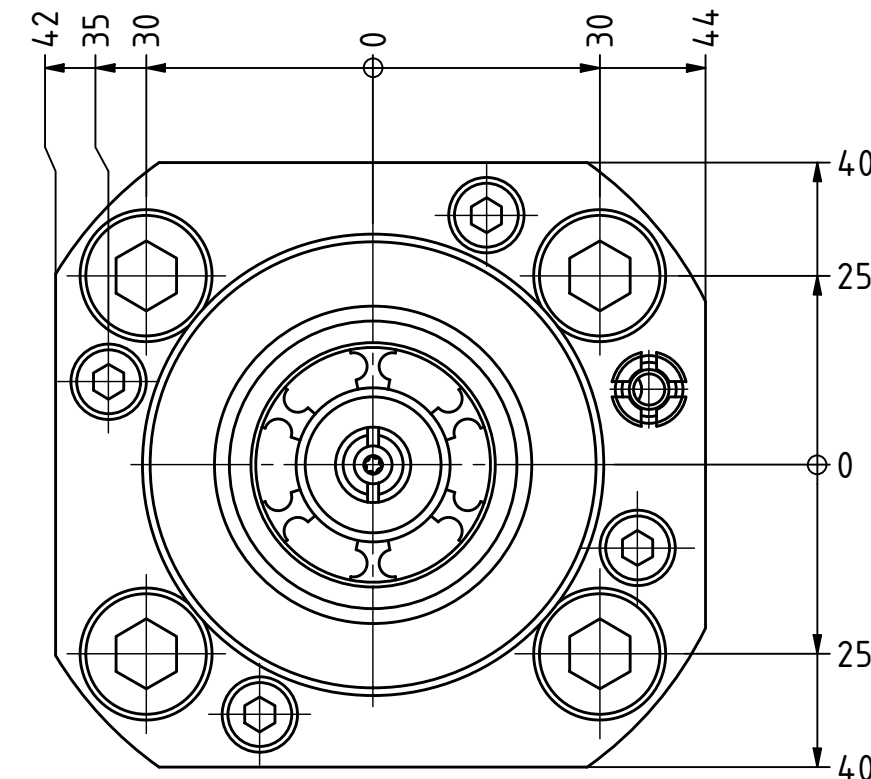
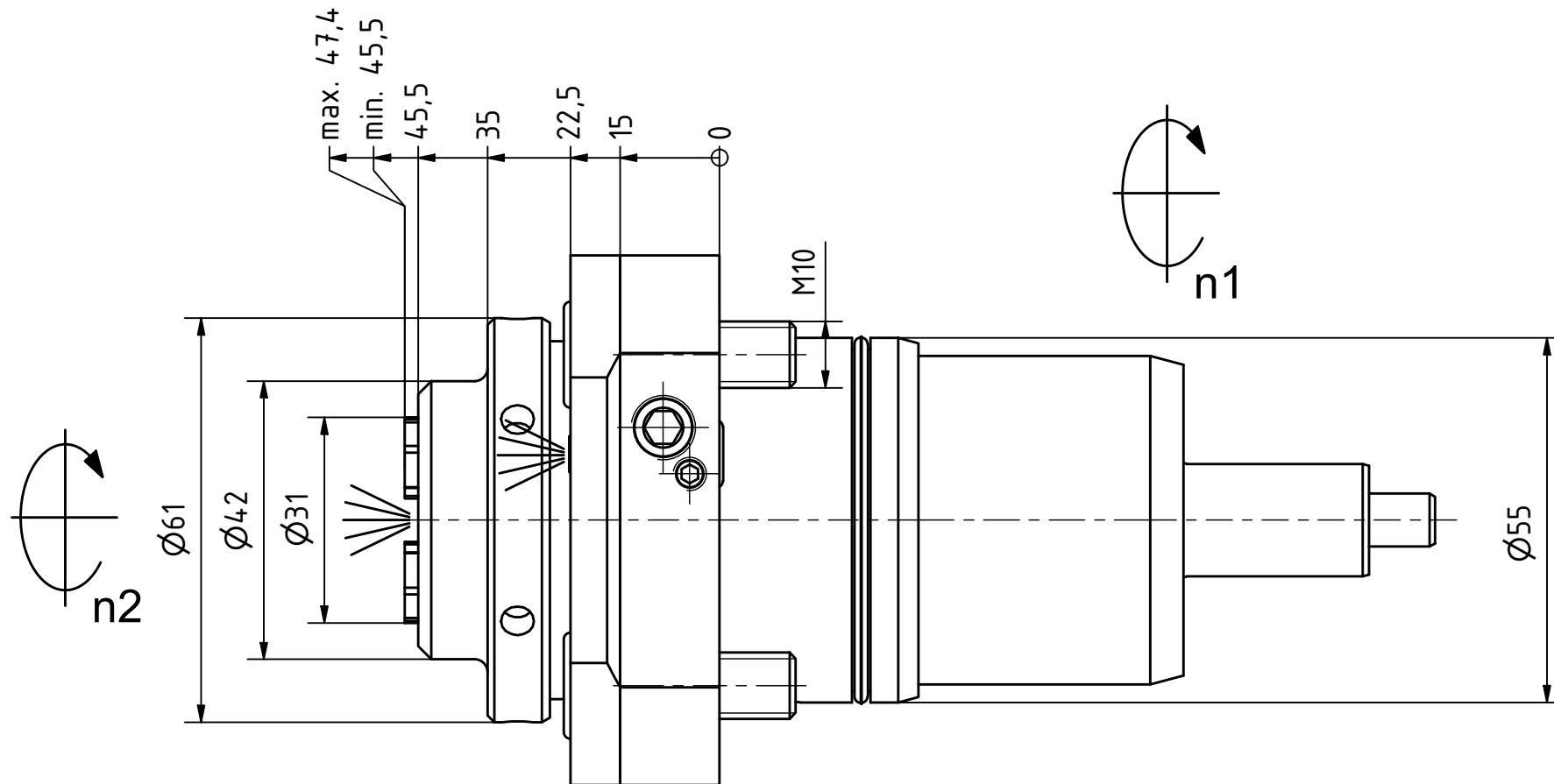

Spannzange / collet ER25 DIN6499  
 Spannbereich / clamping range: 1,0 - 16,0

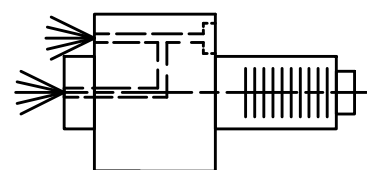

Innen- und Aussenkuehlung / Inside and outside coolant supply  
 Kuehlmittelfiltrierung <math>50\mu</math> / coolant filtration <math>50\mu</math>

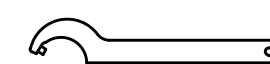
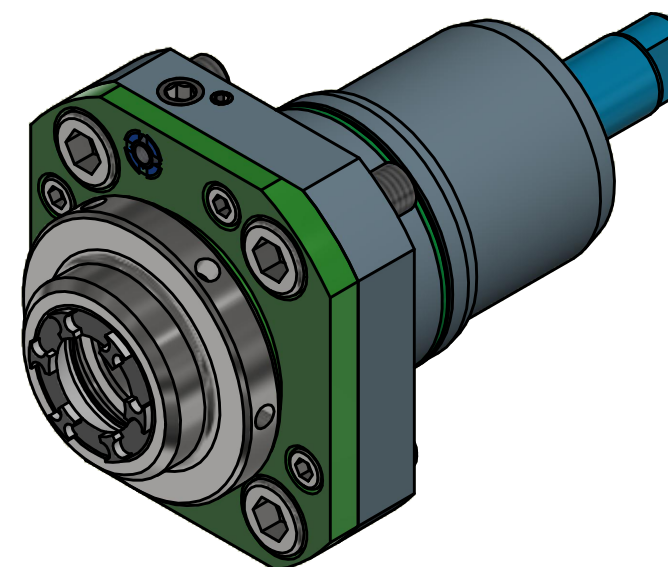

Hakenschlüssel  
 mit Zapfen  
 Hook wrench  
 with fixed pin  
 DIN1810 B 58x62

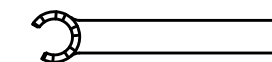

Spannzangenschlüssel für  
 innenliegende Mutter  
 Clamping wrench for  
 internal collet  
 225AX

Copyright **EWS Tool Technologies**

Weitergabe und Vervielfaeltigung dieser Unterlage,  
 Verwertung und Mitteilung ihres Inhalts nicht  
 gestattet, soweit nicht ausdrucklich zugestanden.  
 Zuwiderhandlungen verpflichten zu Schadenersatz.

Bemerkung - Note

Für Trockenlauf geeignet!  
 Use without coolant fluid allowed!

Technische Daten - technical data

Weight = 2.426 [kg]  
 Torque max. (M1/M2) = 25 / 25 [Nm]  
 Speed max. (n1/n2) = 12000 / 12000 [1/min]  
 Gear ratio (i)=n1:n2 = 1:1  
 Pressure (pmax) = 70 [bar]

Benennung - Title

**Axial Bohr und Fräskopf**  
**Axial drilling and milling head**



Nr. - No.

40.5525TW10IKCIMHSD10

Technische Aenderungen vorbehalten!  
 Subject to technical modifications!

IDENT: DEWS140367



REV: -/B

MNR.

216140

