

Spannzange / collet ER25 DIN6499  
Spannbereich / clamping range: 1,0 - 16,0

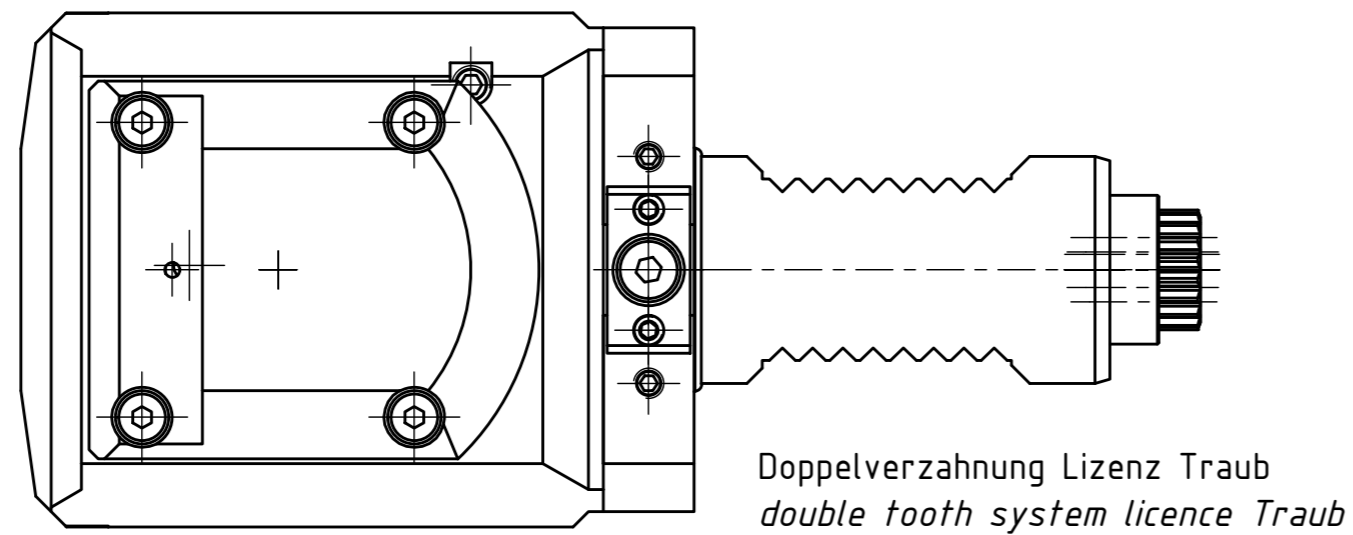

Doppelverzahnung Lizenz Traub  
double tooth system licence Traub

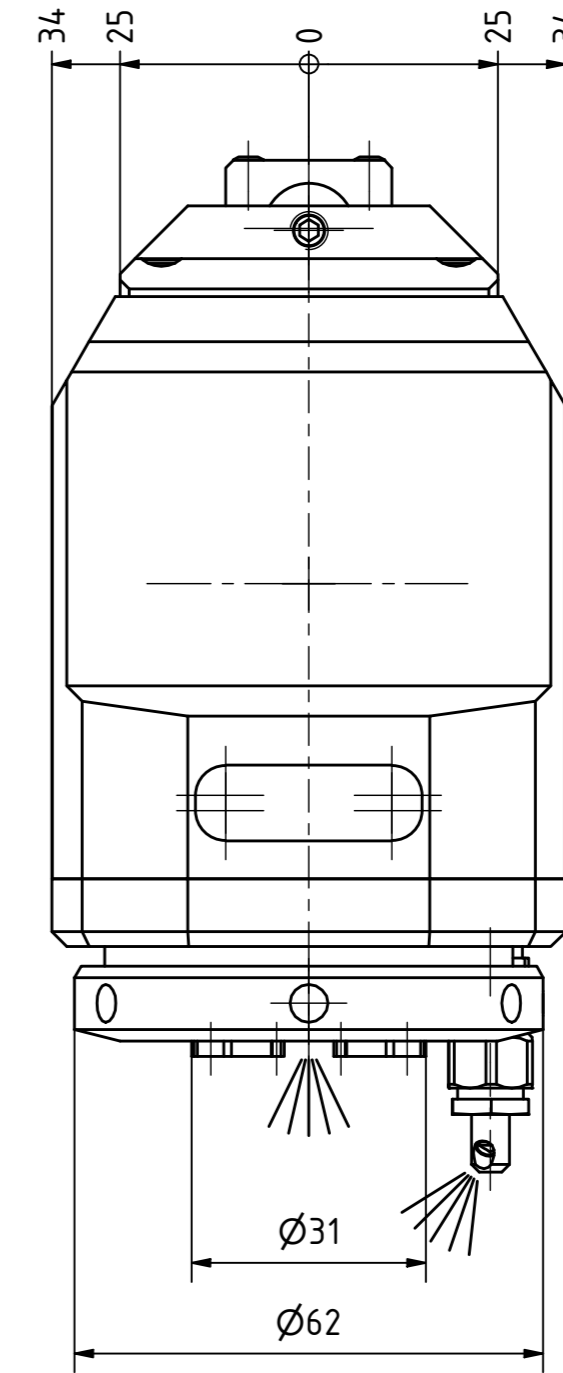
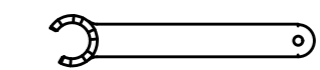
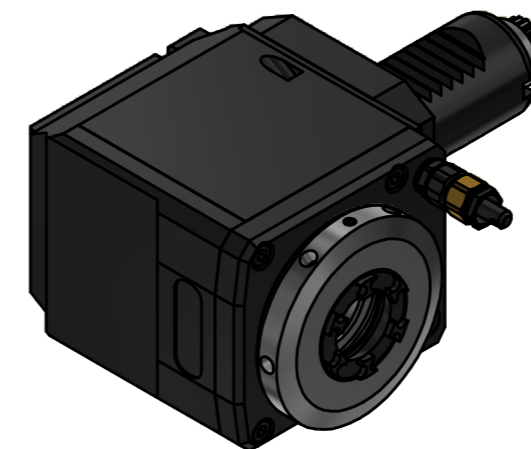

Spannzangenschlüssel für innenliegende Mutter  
Clamping wrench for internal collet  
225AX

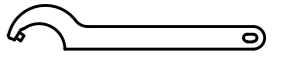

Hakenschlüssel mit Zapfen  
Hook wrench with fixed pin  
DIN1810 B 58x62

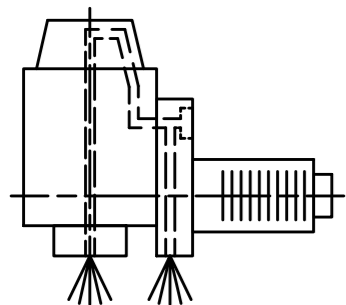

Innen- und Aussenkuehlung / Inside and outside coolant supply  
Kuehlmittelfiltrierung=50µ / coolant filtration=50µ

Copyright **EWS Tool Technologies**  
Weitergabe und Vervielfaeltigung dieser Unterlage, Verwertung und Mitteilung ihres Inhalts nicht gestattet, soweit nicht ausdrucklich zugestanden. Zuwiderhandlungen verpflichten zu Schadenersatz.

Bemerkung - Note Für Trockenlauf geeignet! Use without coolant fluid allowed!	Technische Daten - technical data Weight = 3,490 [kg]
	Torque max. (M1/M2) = 32 / 32 [Nm]
	Speed max. (n1/n2) = 8000 / 8000 [1/min]
	Gear ratio (i)=n1:n2 = 1:1
	Pressure (pmax) = 70 [bar]

Benennung - Title <b>Radial Bohr und Fräskopf</b> <b>Radial drilling and milling head</b>
-------------------------------------------------------------------------------------------------

<b>EWS</b> <small>EWS Weigle GmbH &amp; Co. KG          Maybachstr. 1          D-73066 Uhlingen          www.ews-tool.de</small>	Technische Aenderungen vorbehalten! Subject to technical modifications! IDENT: DEWS229801
	Nr. - No. <b>60.3025CTXRLIKDIM</b>
REV: -/E MNR. <b>213343</b>	

