

W-Verzahnung Lizenz Index-Werke  
W-tooth system licence Index-Corporation

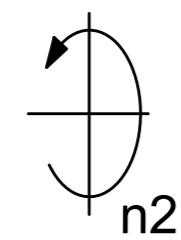

Spannzange / collet ER25 DIN6499  
Spannbereich / clamping range: 1,0 - 16,0

Gewindebohrzange / tapping collet  
ET-1-25 M3-M12

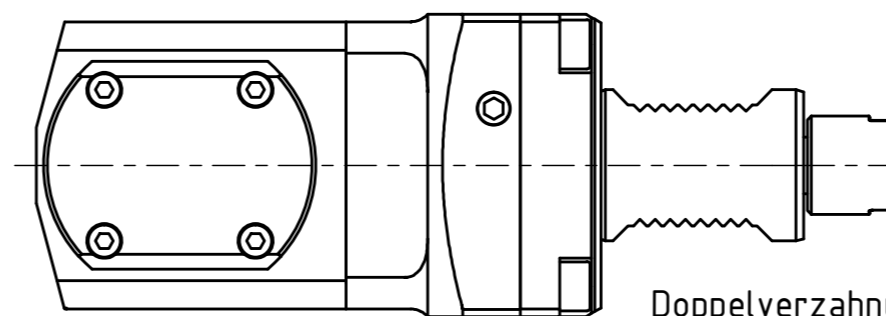
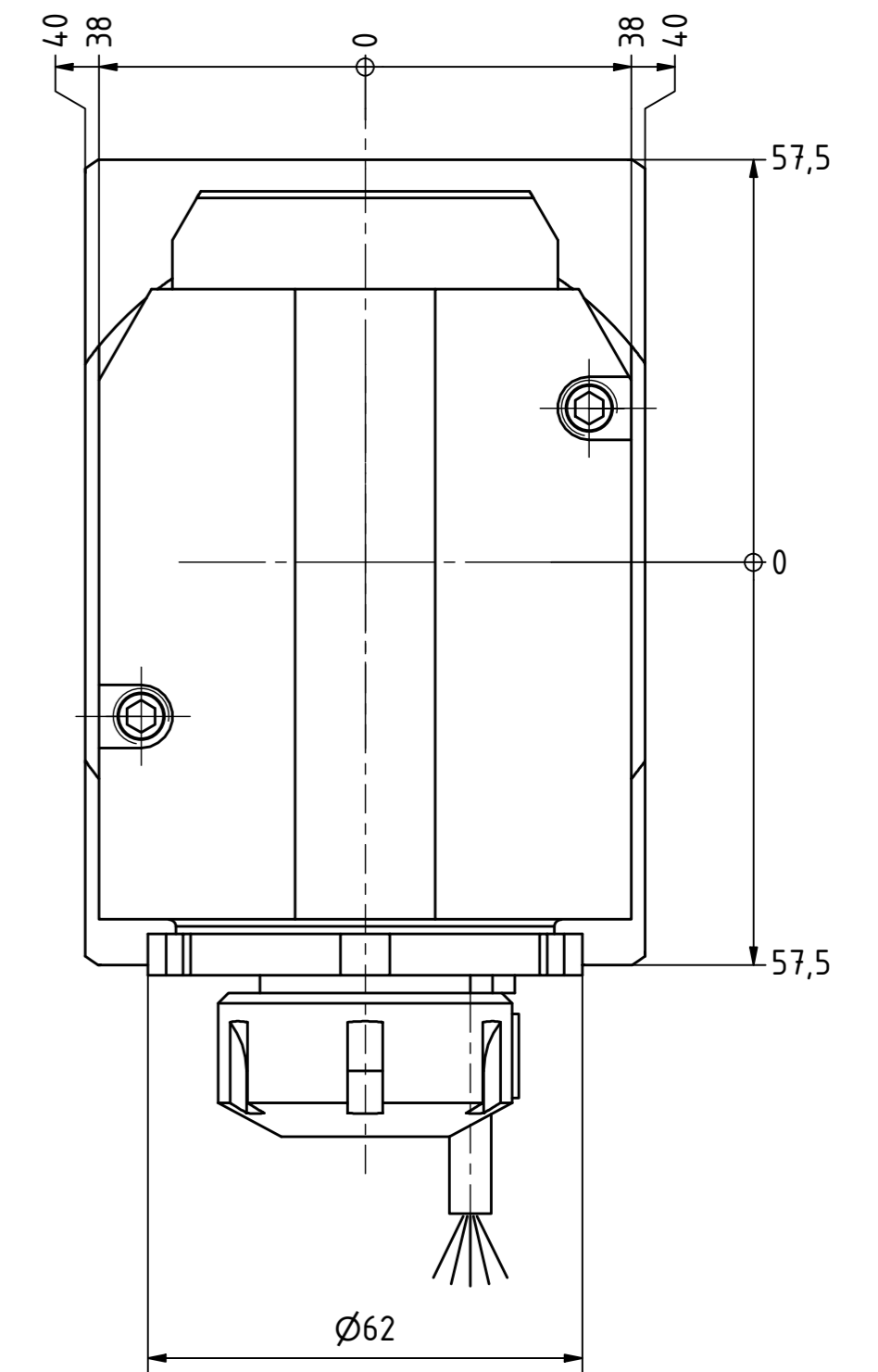
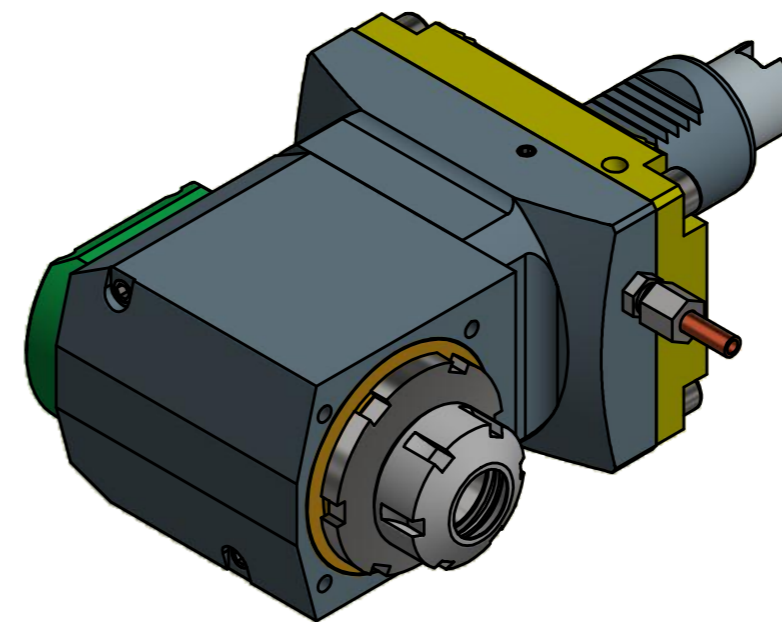

Doppelverzahnung Lizenz Traub  
double tooth system licence Traub

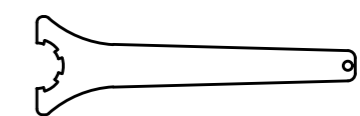

Spannzangenschlüssel  
Clamping wrench  
225

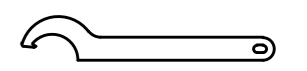

Hakenschlüssel  
mit Nase  
Hook wrench with  
nose end  
DIN1810 A 58x62

Copyright **EWS Tool Technologies**  
Weitergabe und Vervielfältigung dieser Unterlage,  
Verwertung und Mitteilung ihres Inhalts nicht  
gestattet, soweit nicht ausdrücklich zugestanden.  
Zu widerhandlungen verpflichten zu Schadenersatz.

Bemerkung - Note	Technische Daten - technical data Weight = 8,047 [kg] Torque max. (M1/M2) = [Nm] Speed max. (n1/n2) = [1/min] Gear ratio (i)=n1:n2 =	Benennung - Title	 EWS Weigle GmbH & Co. KG Maybachstr. 1 D-73066 Uhlingen www.ews-tools.de	Technische Änderungen vorbehalten! Subject to technical modifications! IDENT: DEWS066360 MNR.	 REV: -/A 212939
		Nr. - No. 60.4025G250RL11WX110			