

Spannzange / collet ER25 DIN6499
 Spannbereich / clamping range: 1,0 - 16,0

Gewindebohrzange / tapping collet
 ET-1-25 M3-M10

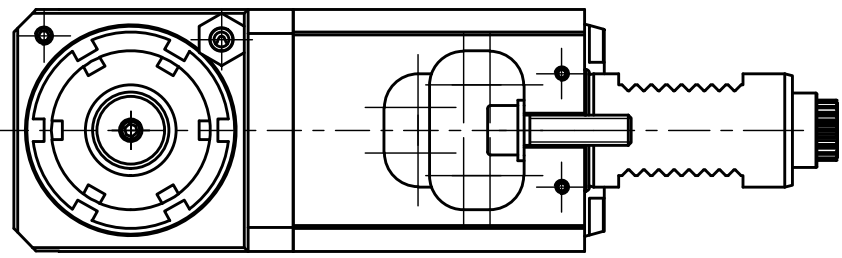

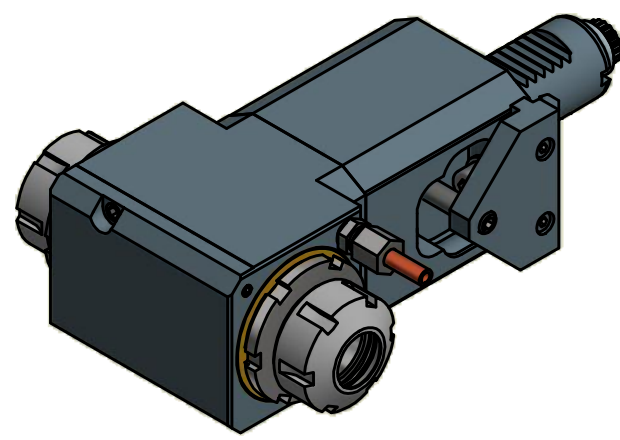

Doppelverzahnung Lizenz Traub
 double tooth system licence Traub



Spannzangenschlüssel
 Clamping wrench
 225

Hakenschlüssel
 mit Nase
 Hook wrench with
 nose end
 DIN1810 A 52x55

Copyright **EWS Tool Technologies**
 Weitergabe und Vervielfältigung dieser Unterlage,
 Verwertung und Mitteilung ihres Inhalts nicht
 gestattet, soweit nicht ausdrücklich zugestanden.
 Zuwiderhandlungen verpflichten zu Schadenersatz.

Bemerkung - Note Technische Daten - technical data Weight = 5.075 [kg] Torque max. (M1/M2) = 25 / 25 [Nm] Speed max. (n1/n2) = 8000 / 8000 [1/min] Gear ratio (i)=n1:n2 = 1:1	Benennung - Title Radial Bohr und Fräskopf <i>Radial drilling and milling head</i>	 EWS Weigele GmbH & Co. KG Maybachstr. 1 D-73066 UHINGEN www.ews-tools.de Technische Änderungen vorbehalten! Subject to technical modifications! IDENT: DEWS074608 Nr. - No. 60.3025LDE365RL-VS	 REV: -/A MNR. 214393	
--	---	---	--	---