

Trifix Anzugsdrehmoment 50 Nm
 Trifix clamping torque 50 Nm

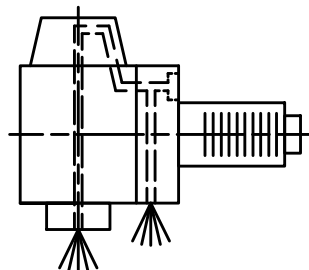
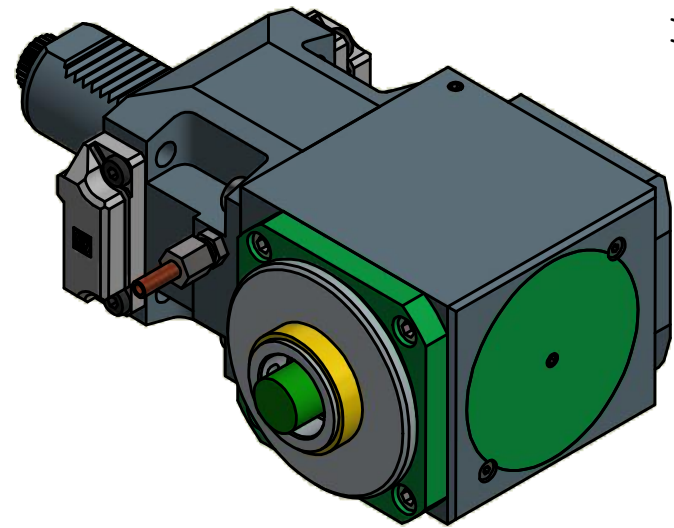

Innen- und Aussenkuehlung / Inside and outside coolant supply
 Kein Trockenlauf / No dry run
 Kuehlmittelfiltrierung <math>< 50\mu</math> / coolant filtration <math>< 50\mu</math>

Copyright **EWS Tool Technologies**
 Weitergabe und Vervielfaeltigung dieser Unterlage,
 Verwertung und Mitteilung ihres Inhalts nicht
 gestattet, soweit nicht ausdrecklich zugestanden.
 Zuwiderhandlungen verpflichten zu Schadenersatz.

<p>Bemerkung - Note</p> <p>Nicht ohne Kuehlmittel betreiben! <i>Not for use without coolant-fluid!</i></p>	<p>Technische Daten - technical data</p> <p>Weight = 10.131 [kg] Torque max. (M1/M2) = 50 / 50 [Nm] Speed max. (n1/n2) = 6000 / 6000 [1/min] Gear ratio (i)=n1:n2 = 1:1 Pressure (pmax) = 70 [bar]</p>	<p>Benennung - Title</p>	<p>EWS Tool Technologies</p> <p><small>EWS Weigle GmbH & Co. KG Maybachstr. 1 D-73066 Uehingen www.ews-tools.de</small></p>	<p>Technische Aenderungen vorbehalten! <i>Subject to technical modifications!</i></p> <p>IDENT: DEWS064406</p>	<p></p> <p>REV: -/A</p> <p>MNR.</p>	<p>QR</p>
			<p>Nr. - No.</p> <p>60.40HSK40LCTXLIKTF</p>			<p>211313</p>