

Spannzange / collet ER32 DIN6499  
 Spannbereich / clamping range: 2,0 - 20,0

Gewindebohrzange / tapping collet  
 ET-1-32 M5-M12

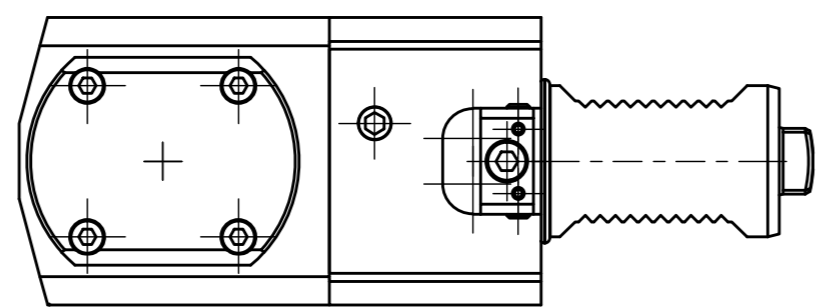

Doppelverzahnung Lizenz Traub  
 double tooth system licence Traub

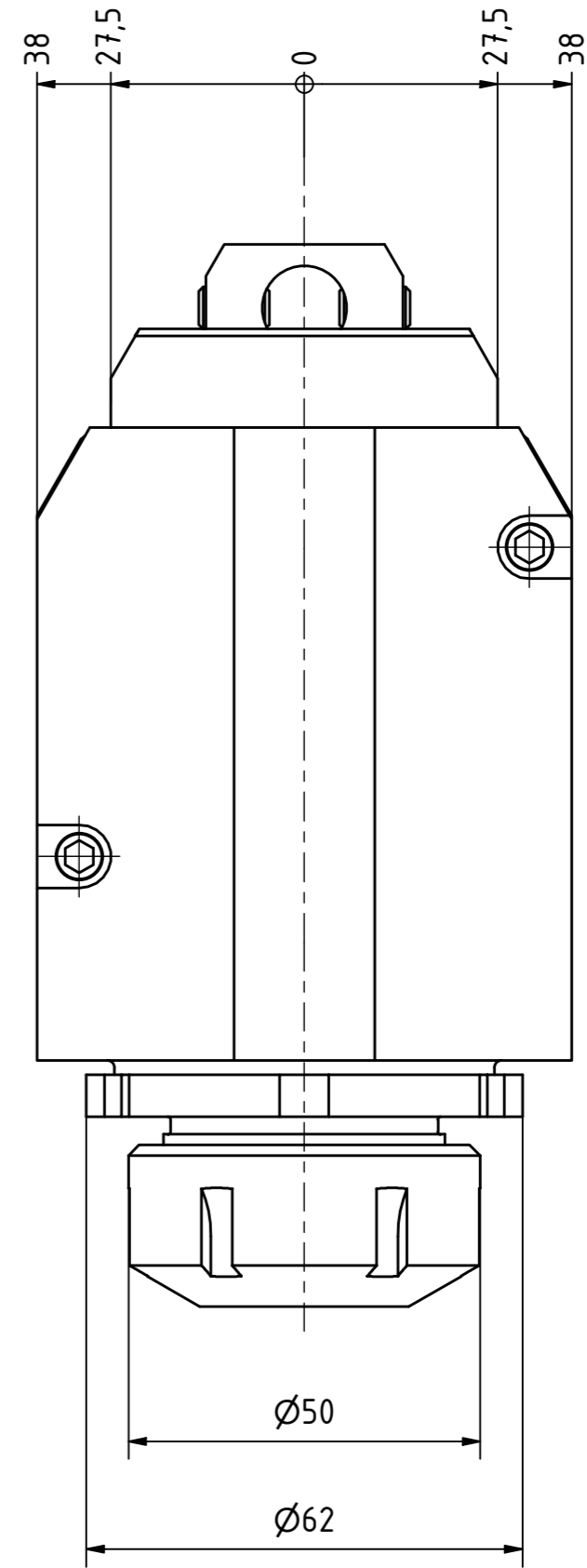
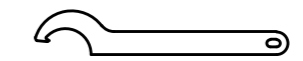
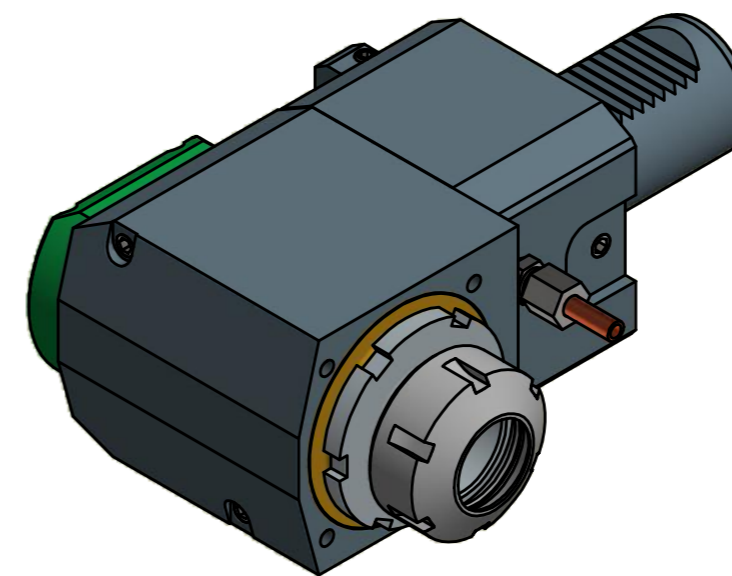

Hakenschlüssel  
 mit Nase  
 Hook wrench with  
 nose end  
 DIN1810 A 58x62

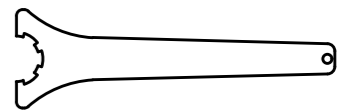

Spannzangenschlüssel  
 Clamping wrench  
 232

Copyright **EWS Tool Technologies**  
 Weitergabe und Vervielfältigung dieser Unterlage,  
 Verwertung und Mitteilung ihres Inhalts nicht  
 gestattet, soweit nicht ausdrücklich zugestanden.  
 Zuwiderhandlungen verpflichten zu Schadenersatz.

Bemerkung - Note

Technische Daten - technical data  
 Weight = 6.416 [kg]  
 Torque max. (M1/M2) = 50 / 25 [Nm]  
 Speed max. (n1/n2) = 6000 / 12000 [1/min]  
 Gear ratio (i)=n1:n2 = 1:2

Benennung - Title

Radial Bohr und Fräskopf  
 Radial drilling and milling head



EWS Weigle GmbH & Co. KG  
 Maybachstr. 1  
 D-73066 Ulm/geringen  
 www.ews-tool.de  
 Nr. - No.  
 60.40321809RLI1PIN56X100

Technische Änderungen vorbehalten!  
 Subject to technical modifications!  
 IDENT: DEWS072780

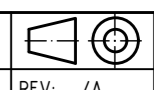

REV: -/A  
 MNR.  
 214043

QR