

Doppelverzahnung Lizenz Traub
double tooth system licence Traub

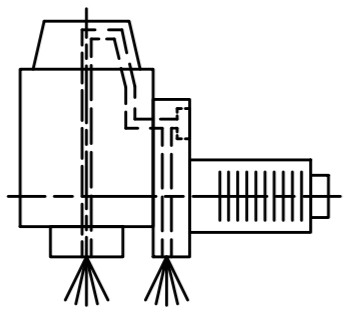

Innen- und Aussenkuehlung / inside and outside coolant supply
Kuehlmitelfiltrierung-50µ / coolant filtration-50µ

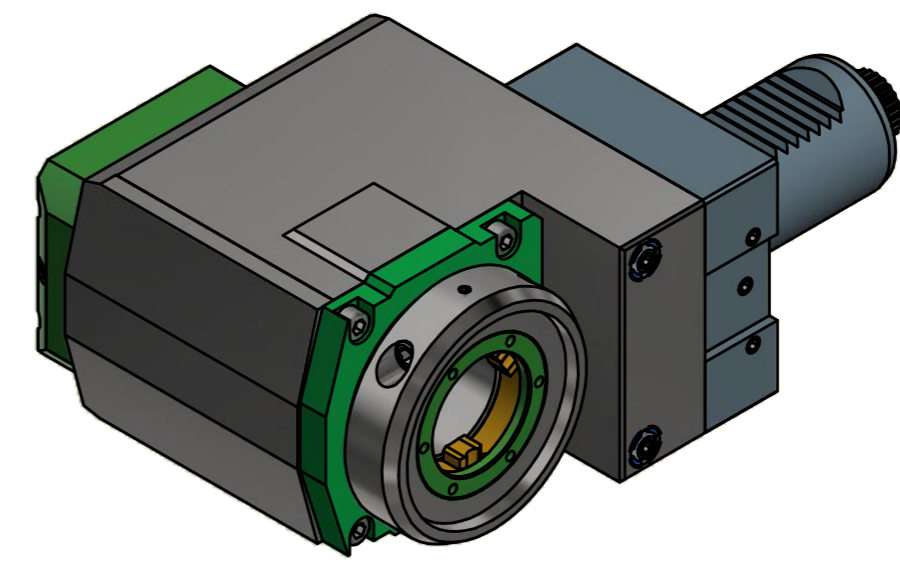

Copyright **EWS Tool Technologies**
Weitergabe und Vervielfaeltigung dieser Unterlage,
Verwertung und Mitteilung ihres Inhalts nicht
gestattet, soweit nicht ausdrecklich zugestanden.
Zuwiderhandlungen verpflichten zu Schadenersatz.

Bemerkung - Note Für Trockenlauf geeignet! <i>Use without coolant fluid allowed!</i> mit Kegelrollenlager <i>with taper roller bearing(s)</i>	Technische Daten - technical data Weight = 8.375 [kg] Torque max. (M1/M2) = 40 / 80 [Nm] Speed max. (n1/n2) = 6000 / 3000 [1/min] Gear ratio (i)=n1:n2 = 2:1 Pressure (pmax) = 70 [bar]
---	---

Benennung - Title Radial Bohr und Fräskopf, zurückges <i>Radial drill. and mill. head offset</i>

EWS <small>EWS Weigle GmbH & Co. KG Maybachstr. 1 D-73066 Uhlingen www.ews-tools.de</small>	Technische Aenderungen vorbehalten! <i>Subject to technical modifications!</i> IDENT: DEWS063974	REV: -/A MNR.
	Nr. - No. 80.40VX4KRCTXRLIKD12	212224

