

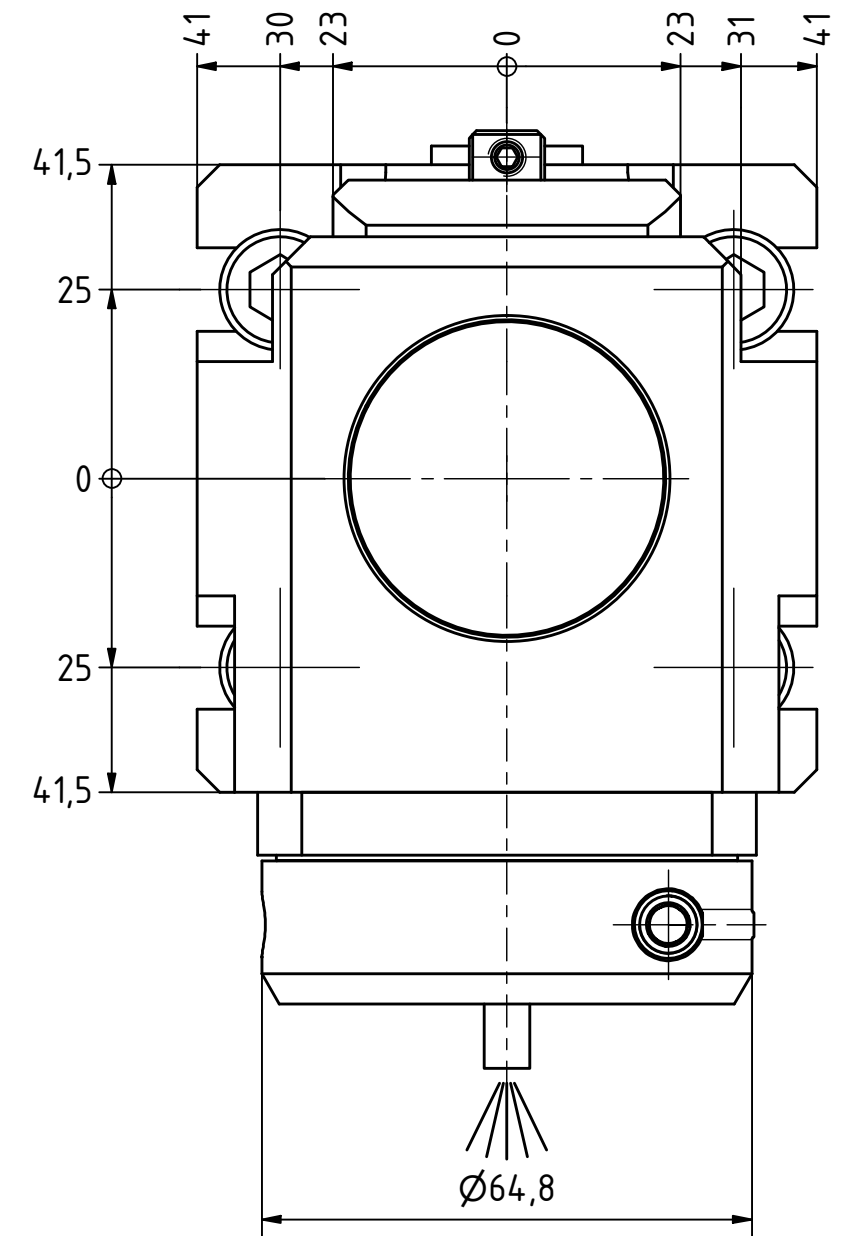

EWS.Varia

Ceramic Seal

Tech Details

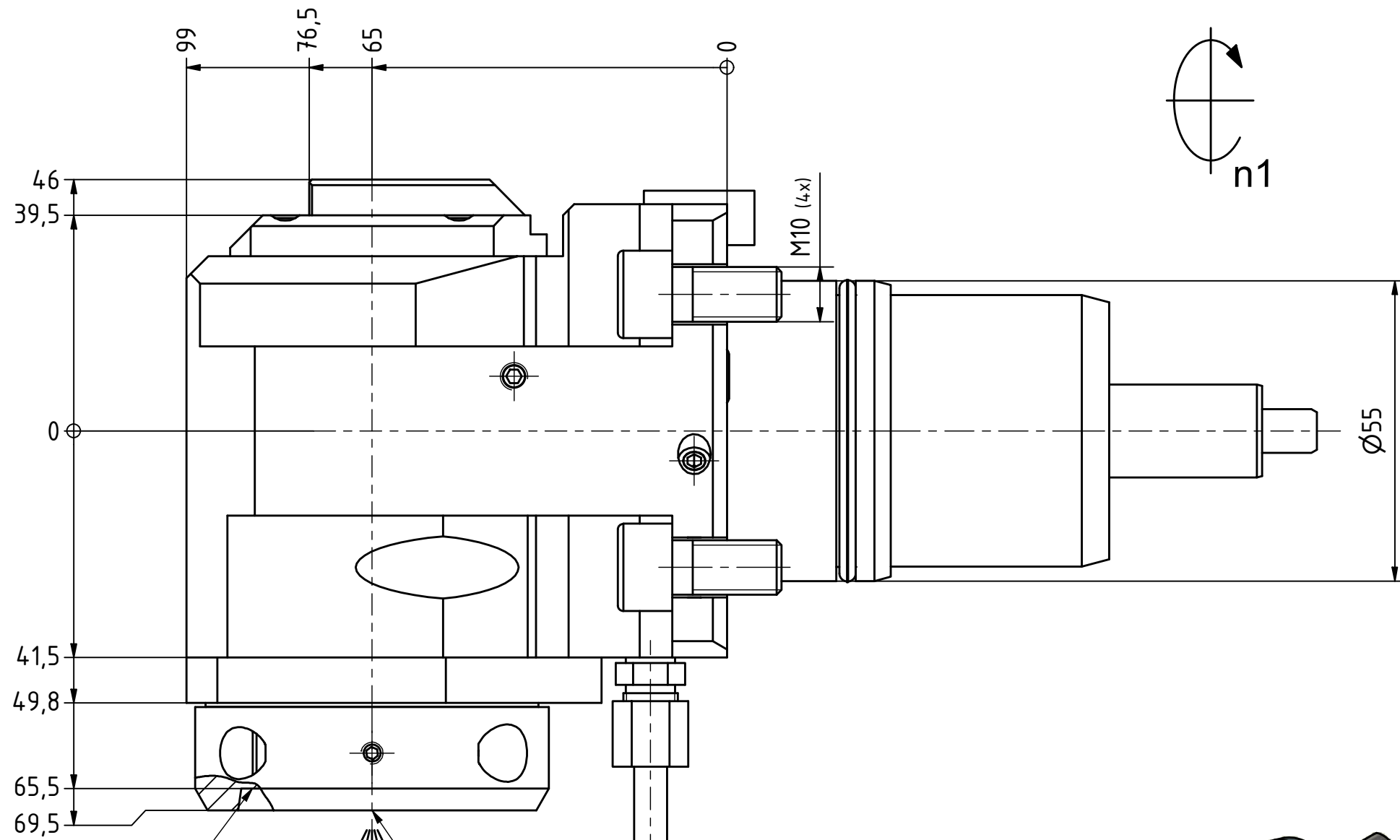

Anlagefläche  
contact surface

EWS-Varia VX3

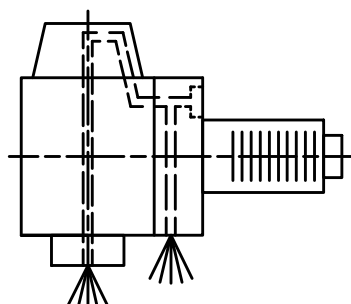

Innen- und Aussenkuehlung / Inside and outside coolant supply  
Kuehlmittelfiltrierung<50µ / coolant filtration<50µ

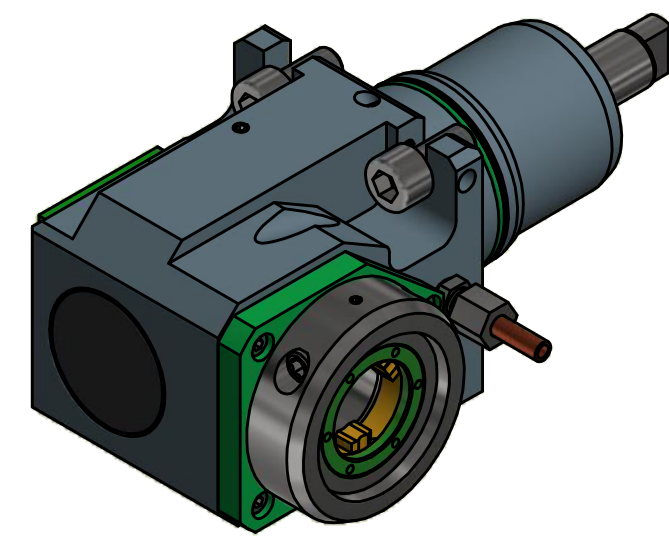

Copyright **EWS Tool Technologies**  
Weitergabe und Vervielfaeltigung dieser Unterlage,  
Verwertung und Mitteilung ihres Inhalts nicht  
gestattet, soweit nicht ausdrecklich zugestanden.  
Zuwiderhandlungen verpflichten zu Schadenersatz.

Bemerkung - Note  
Für Trockenlauf geeignet!  
Use without coolant fluid allowed!

Technische Daten - technical data	
Weight	= 4.819 [kg]
Torque max. (M1/M2)	= 25 / 25 [Nm]
Speed max. (n1/n2)	= 6000 / 6000 [1/min]
Gear ratio (i)=n1:n2	= 1:1
Pressure (pmax)	= 70 [bar]

Benennung - Title  
**Radial Bohr und Fräskopf**  
*Radial drilling and milling head*

**EWS** Tool Technologies  
EWS Weigle GmbH & Co. KG  
Maybachstr. 1  
D-73066 Utingen  
www.ews-tools.de

Technische Aenderungen vorbehalten!  
Subject to technical modifications!  
IDENT: DEWS104754  
REV: -/A  
MNR.  
211106

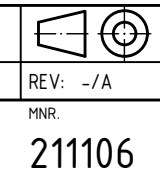

**QR**

Nr. - No.  
**60.55VX3WT150IKDX65**