

Innen- und Aussenkuehlung / Inside and outside coolant supply
Kuehlmittelfiltrierung 50μ / coolant filtration 50μ

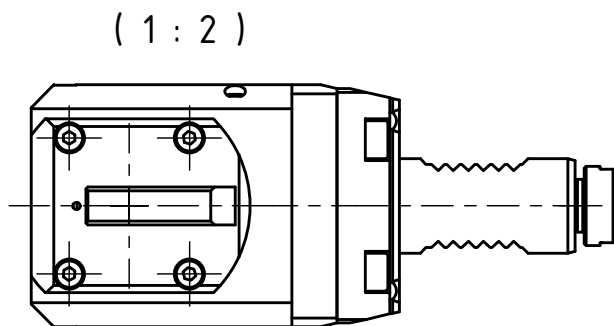

Doppelverzahnung Lizenz Traub
double tooth system licence Traub

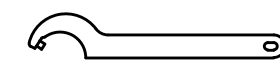
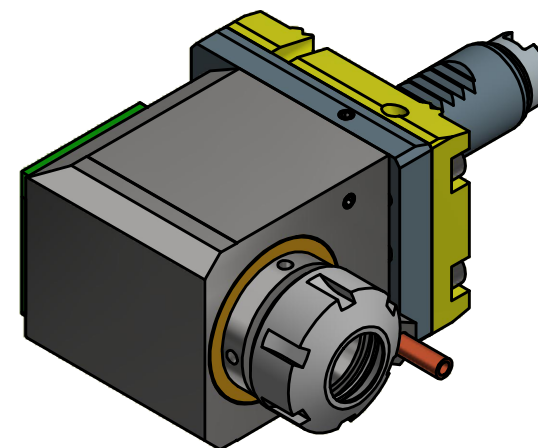

Hakenschlüssel
mit Zapfen
Hook wrench
with fixed pin
DIN1810 B 40x42

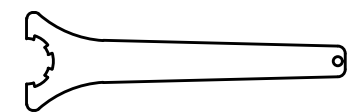

Spannzangenschlüssel
Clamping wrench
DIN 225

Copyright **EWS Tool Technologies**
Weitergabe und Vervielfaeltigung dieser Unterlage,
Verwertung und Mitteilung ihres Inhalts nicht
gestattet, soweit nicht ausdrecklich zugestanden.
Zuwiderhandlungen verpflichten zu Schadenersatz.

Bemerkung - Note
Für Trockenlauf geeignet!
Use without coolant fluid allowed!

Technische Daten - technical data
Weight = 3.222 [kg]
Torque max. (M1/M2) = 25 / 25 [Nm]
Speed max. (n1/n2) = 8000 / 8000 [1/min]
Gear ratio (i)=n1:n2 = 1:1
Pressure (pmax) = 70 [bar]

Benennung - Title
Radial Bohr und Fräskopf
Radial drilling and milling head

EWS
Tool Technologies
EWS Weigle GmbH & Co. KG
Maybachstr. 1
D-73066 UHINGEN
www.ews-tools.de

Technische Aenderungen vorbehalten!
Subject to technical modifications!

IDENT: DEWS053845



REV: -/A

Nr. - No.
60.2525G200RLIKDGLW

MNR.
209586

QR