

Spannzange / collet ER25 DIN6499
 Spannbereich / clamping range: 1,0 - 16,0

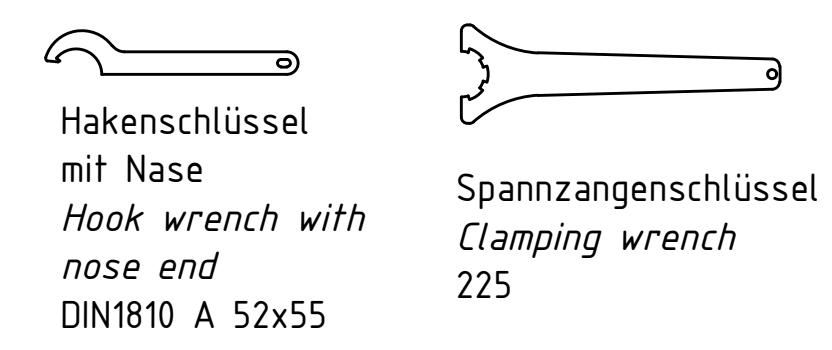
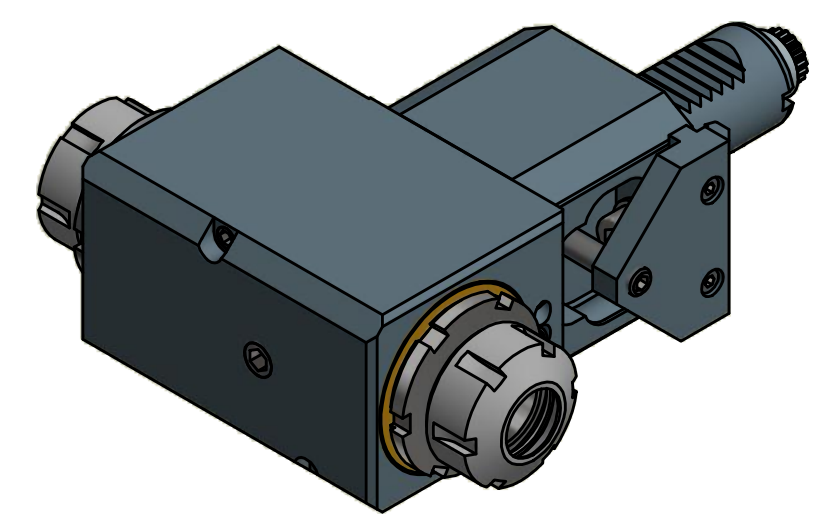
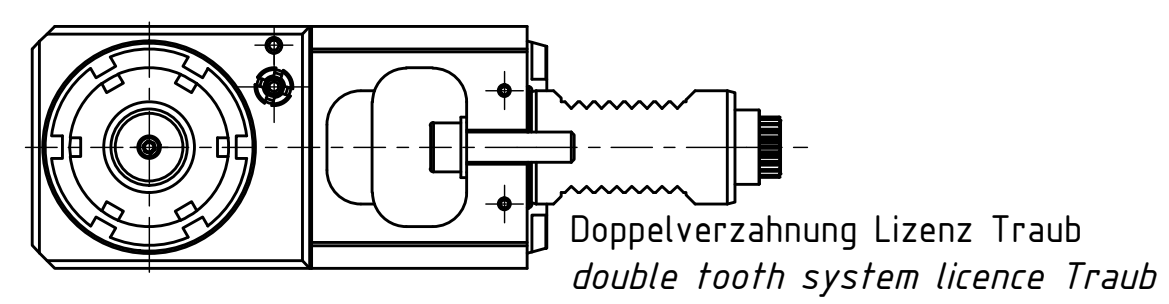

Copyright **EWS Tool Technologies**
 Weitergabe und Vervielfältigung dieser Unterlage, Verwertung und Mitteilung ihres Inhalts nicht gestattet, soweit nicht ausdrücklich zugestanden. Zuwiderhandlungen verpflichten zu Schadenersatz.

Innen- und Aussenkühlung / Inside and outside coolant supply
 Kein Trockenlauf / No dry run
 Kühlmittelfiltrierung-50µ / coolant filtration-50µ

Bemerkung - Note Nicht ohne Kuehlmittel betreiben! Not for use without coolant-fluid!	Technische Daten - technical data Weight = 5,490 [kg] Torque max. (M1/M2) = 25 / 25 25 [Nm] Speed max. (n1/n2) = 8000 / 8000 8000 [1/min] Gear ratio (i)=n1:n2 = 1:1 1:1 Pressure (pmax) = 70 [bar]	Benennung - Title
---	--	-------------------

EWS <small>EWS Weigle GmbH & Co. KG Maybachstr. 1 D-73066 Uhlingen www.ews-tools.de</small>	<small>Technische Aenderungen vorbehalten! Subject to technical modifications!</small>	
	<small>IDENT: DEWS086453</small>	
<small>Nr. - No.</small> 60.3025DE365RLIK-VS	<small>MNR.</small> 210330	QR