

Spannzange / collet ER25 DIN6499
 Spannungsbereich / clamping range: 1,0 - 16,0

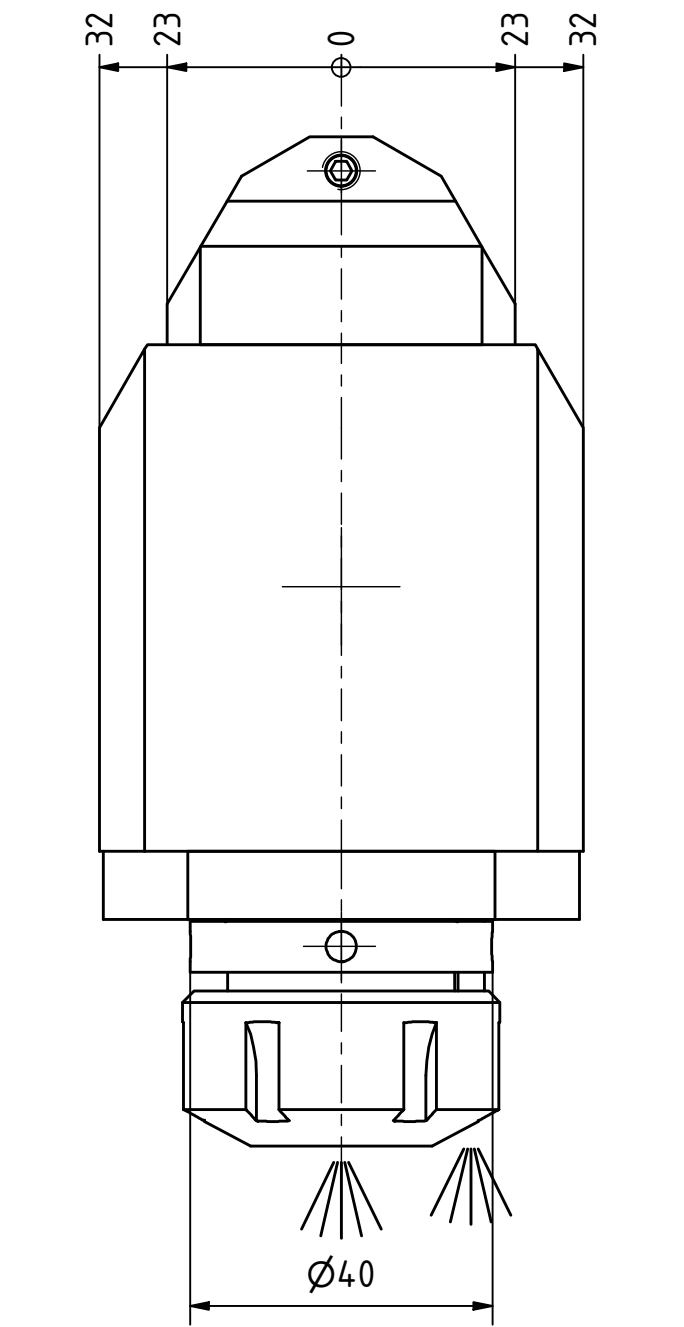

Hakenschlüssel mit Zapfen
 Hook wrench with fixed pin
 DIN1810 B 40x42

Spannzangenschlüssel
 Clamping wrench
 225

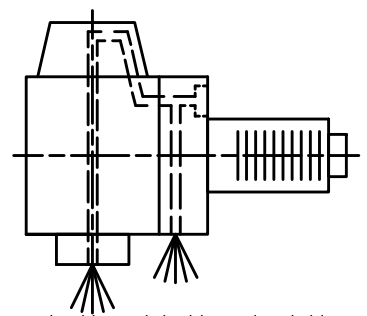
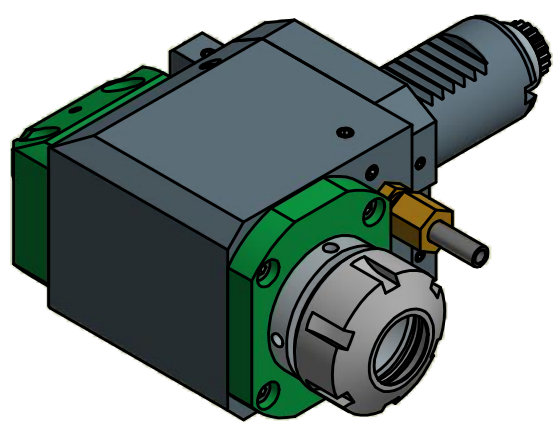

Innen- und Aussenkuehlung / Inside and outside coolant supply
 Kein Trockenlauf / No dry run
 Kuehlmittelfiltrierung-50µ / coolant filtration-50µ

Copyright **EWS Tool Technologies**
 Weitergabe und Vervielfaeltigung dieser Unterlage,
 Verwertung und Mitteilung ihres Inhalts nicht
 gestattet, soweit nicht ausdrecklich zugestanden.
 Zuwiderhandlungen verpflichten zu Schadenersatz.

<p>Bemerkung - Note</p> <p>Nicht ohne Kuehlmittel betreiben! <i>Not for use without coolant-fluid!</i></p> <p>mit Kegelrollenlager <i>with taper roller bearing(s)</i></p>	<p>Technische Daten - technical data</p> <p>Weight = 3.177 [kg] Torque max. (M1/M2) = 25 / 25 [Nm] Speed max. (n1/n2) = 5000 / 5000 [1/min] Gear ratio (i)=n1:n2 = 1:1 Pressure (pmax) = 70 [bar]</p>	<p>Benennung - Title</p> <p>EWS Weigele GmbH & Co. KG Maybachstr. 1 D-73066 Uhingen www.ews-tools.de</p> <p>Technische Aenderungen vorbehalten! <i>Subject to technical modifications!</i></p> <p>IDENT: DEWS046847</p> <p>Nr. - No. 60.3025KRCTXRIK</p>	<p>REV: -/A</p> <p>MNR. 208298</p>	
--	---	--	---	---