

Kühlmittelezufuhr
coolant supply

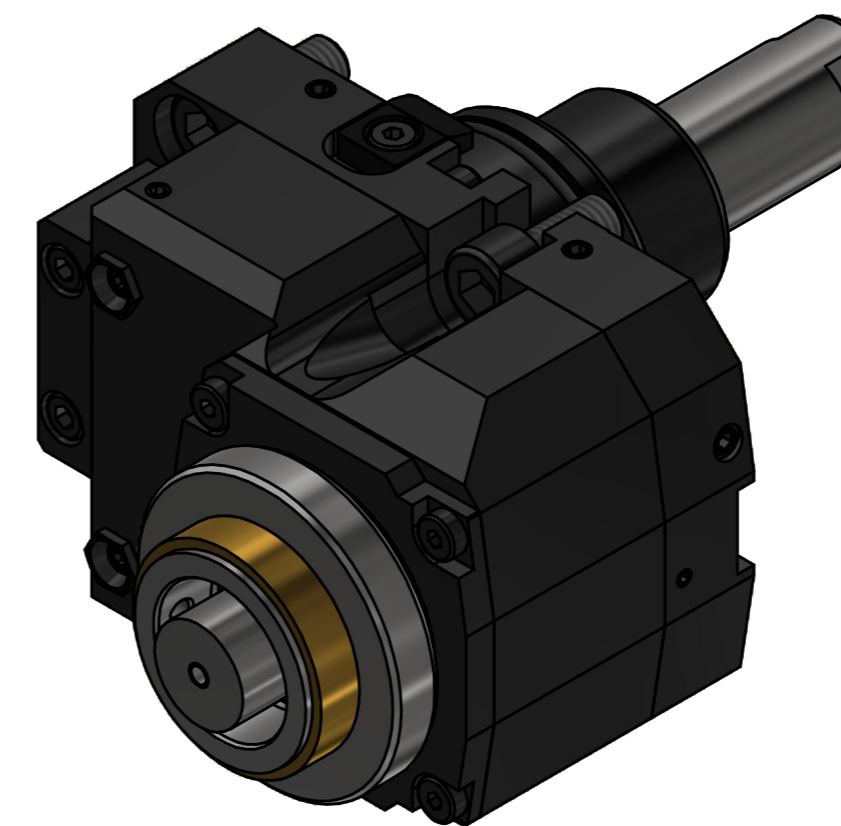

MMS - max. 10 bar
MQL - max. 10 bar

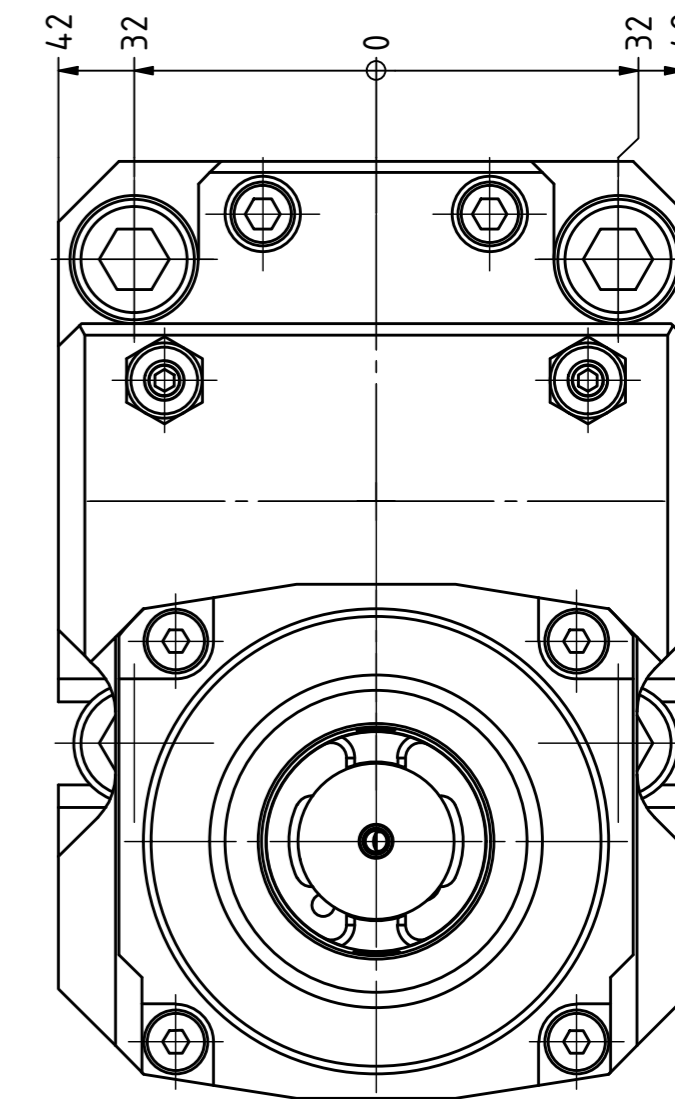
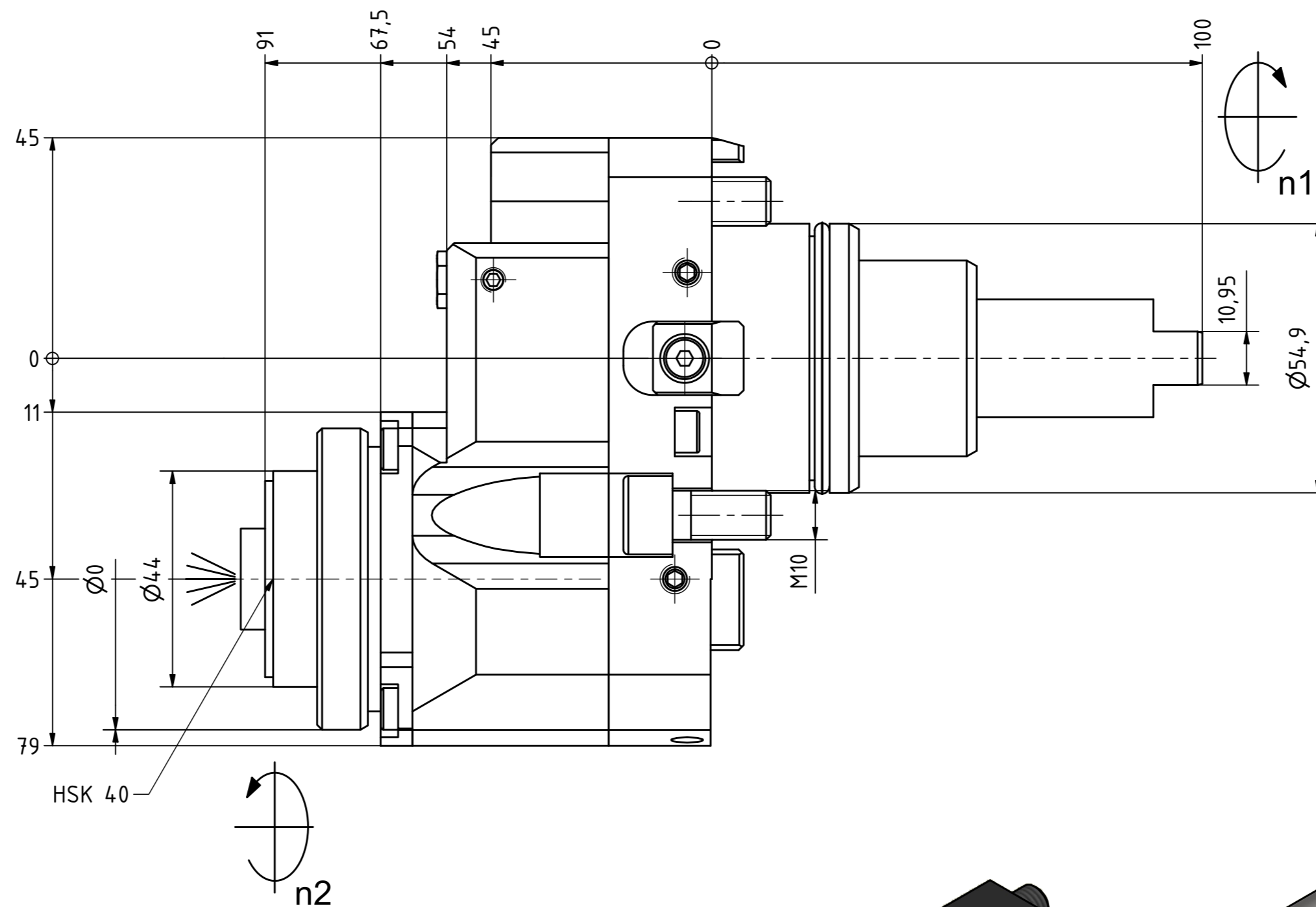
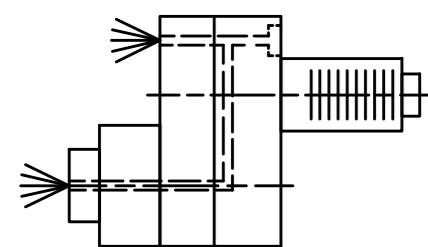

Innen- und Aussenkuehlung / Inside and outside coolant supply
Kuehlmittefiltrierung50μ / coolant filtration50μ

Copyright **EWS Tool Technologies**
Weitergabe und Vervielfaeltigung dieser Unterlage,
Verwertung und Mitteilung ihres Inhalts nicht
gestattet, soweit nicht ausdrecklich zugestanden.
Zuwoerhandlungen verpflichten zu Schadenersatz.

<p>Bemerkung - Note Für Trockenlauf geeignet! Use without coolant fluid allowed!</p>	<p>Technische Daten - technical data Weight = 4.888 [kg] Torque max. (M1/M2) = 48 / 16 [Nm] Speed max. (n1/n2) = 6000 / 18000 [1/min] Gear ratio (i)=n1:n2 = 1:3 Pressure (pmax) = 10 [bar]</p>	<p>Benennung - Title Axial Bohr u. Fräskopf achsversetzt Ax. drill. and mill. head offset</p>	<p>EWS Tool Technologies EWS Weigle GmbH & Co. KG Maybachstr. 1 D-73066 Uhlingen www.ews-tools.de</p>	<p>Technische Aenderungen vorbehalten! Subject to technical modifications! IDENT: DEWS14.7663 REV: -/D MNR. 209480</p>
--	---	---	--	--

