

Doppelverzahnung Lizenz Traub
double tooth system licence Traub

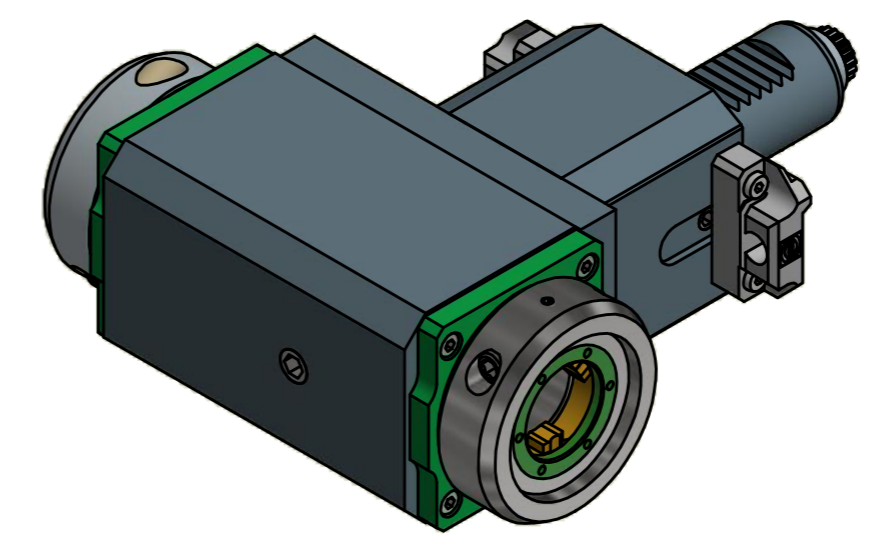

Copyright **EWS Tool Technologies**
Weitergabe und Vervielfältigung dieser Unterlage,
Verwertung und Mitteilung ihres Inhalts nicht
gestattet, soweit nicht ausdrücklich zugestanden.
Zuwerhandlungen verpflichten zu Schadenersatz.

Innen- und Aussenkuehlung / Inside and outside coolant supply
Kein Trockenlauf / No dry run
Kuehlmittelfiltrierung-50µ / coolant filtration-50µ

Bemerkung - Note Nicht ohne Kuehlmittel betreiben! Not for use without coolant-fluid!	Technische Daten - technical data
	Weight = 6.805 [kg]
	Torque max. (M1/M2) = 25 / 25 [Nm]
	Speed max. (n1/n2) = 10000 / 10000 [1/min]
	Gear ratio (i)=n1:n2 = 1:1
Pressure (pmax) = 25 [bar]	

Benennung - Title
Radial Bohr und Fräskopf
Radial drilling and milling head

 EWS Weigle GmbH & Co. KG Maybachstr. 1 D-73066 Uhlingen www.ews-tools.de	Technische Aenderungen vorbehalten! Subject to technical modifications!	 REV: -/A
	IDENT: DEWS051968	
Nr. - No. 60.30VX3LDCTXRLIKTFLHSD10	MNR. 209220	 QR