

Spannzange / collet ER32 DIN6499  
Spannbereich / clamping range: 2,0 - 20,0

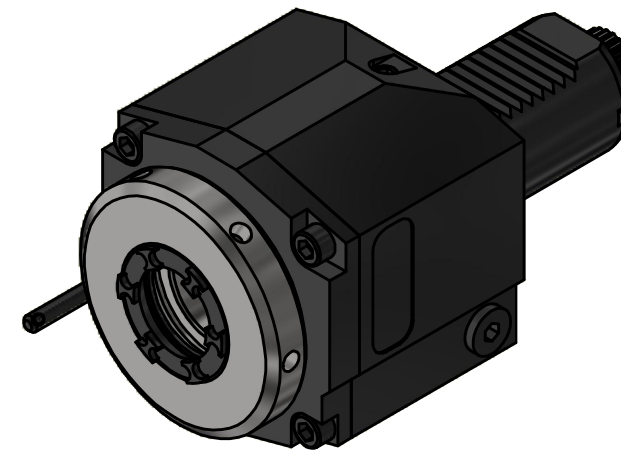
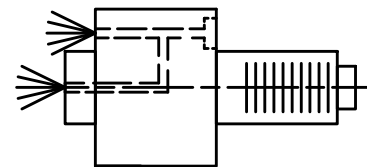

Hakenschlüssel  
mit Zapfen  
Hook wrench  
with fixed pin  
DIN1810 B 68x75

Spannzangenschlüssel für  
innenliegende Mutter  
Clamping wrench for  
internal collet  
232AX

Innen- und Aussenkuehlung / Inside and outside coolant supply  
Kuehlmittelfiltrierung<50µ / coolant filtration<50µ

Copyright **EWS Tool Technologies**  
Weitergabe und Vervielfaeltigung dieser Unterlage,  
Verwertung und Mitteilung ihres Inhalts nicht  
gestattet, soweit nicht ausdrecklich zugestanden.  
Zuwiderhandlungen verpflichten zu Schadenersatz.

Bemerkung - Note  
Für Trockenlauf geeignet!  
Use without coolant fluid allowed!  
mit Kegelrollenlager  
with taper roller bearing(s)

Technische Daten - technical data  
Weight = 4.322 [kg]  
Torque max. (M1/M2) = 50 / 50 [Nm]  
Speed max. (n1/n2) = 5000 / 5000 [1/min]  
Gear ratio (i)=n1:n2 = 1:1  
Pressure (pmax) = 70 [bar]

Benennung - Title  
**Axial Bohr und Fräskopf**  
**Axial drilling and milling head**



Nr. - No.  
**40.4032KRCTXIKCIM**

Technische Aenderungen vorbehalten!  
Subject to technical modifications!  
IDENT: DEWS154939

REV: -/C  
MNR.  
**207427**

