

Polygon ISO 26623 PSC 50

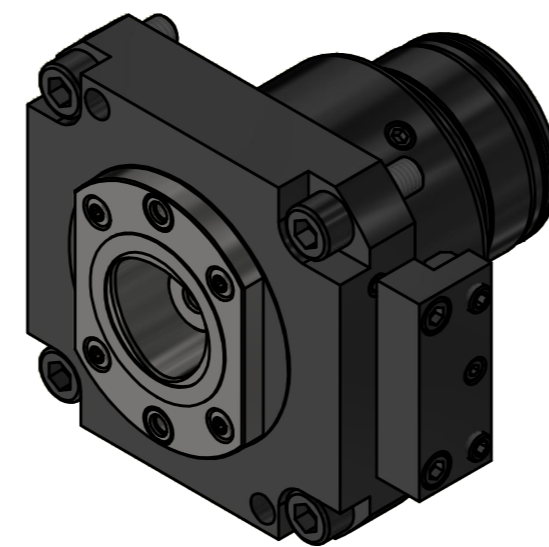
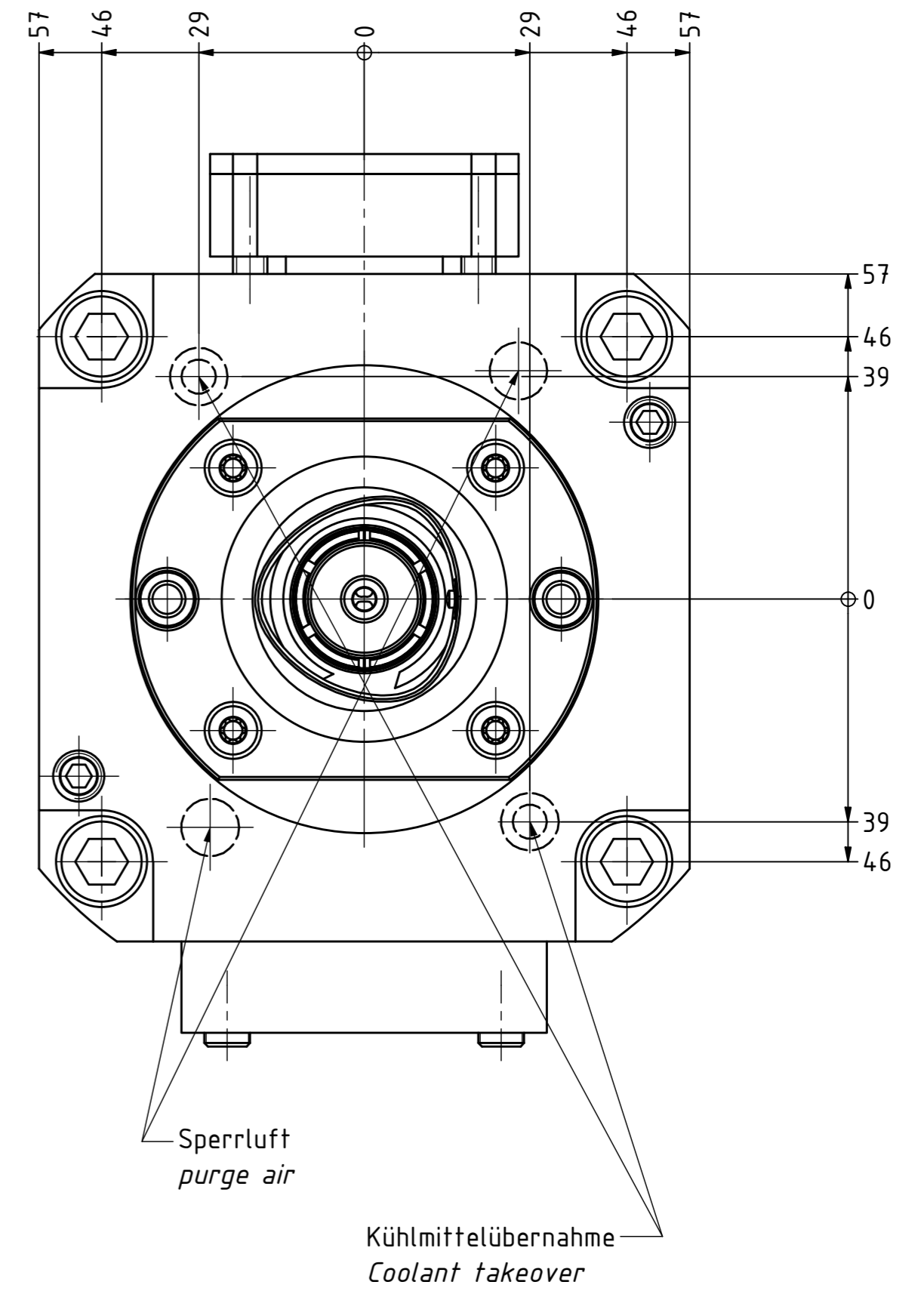
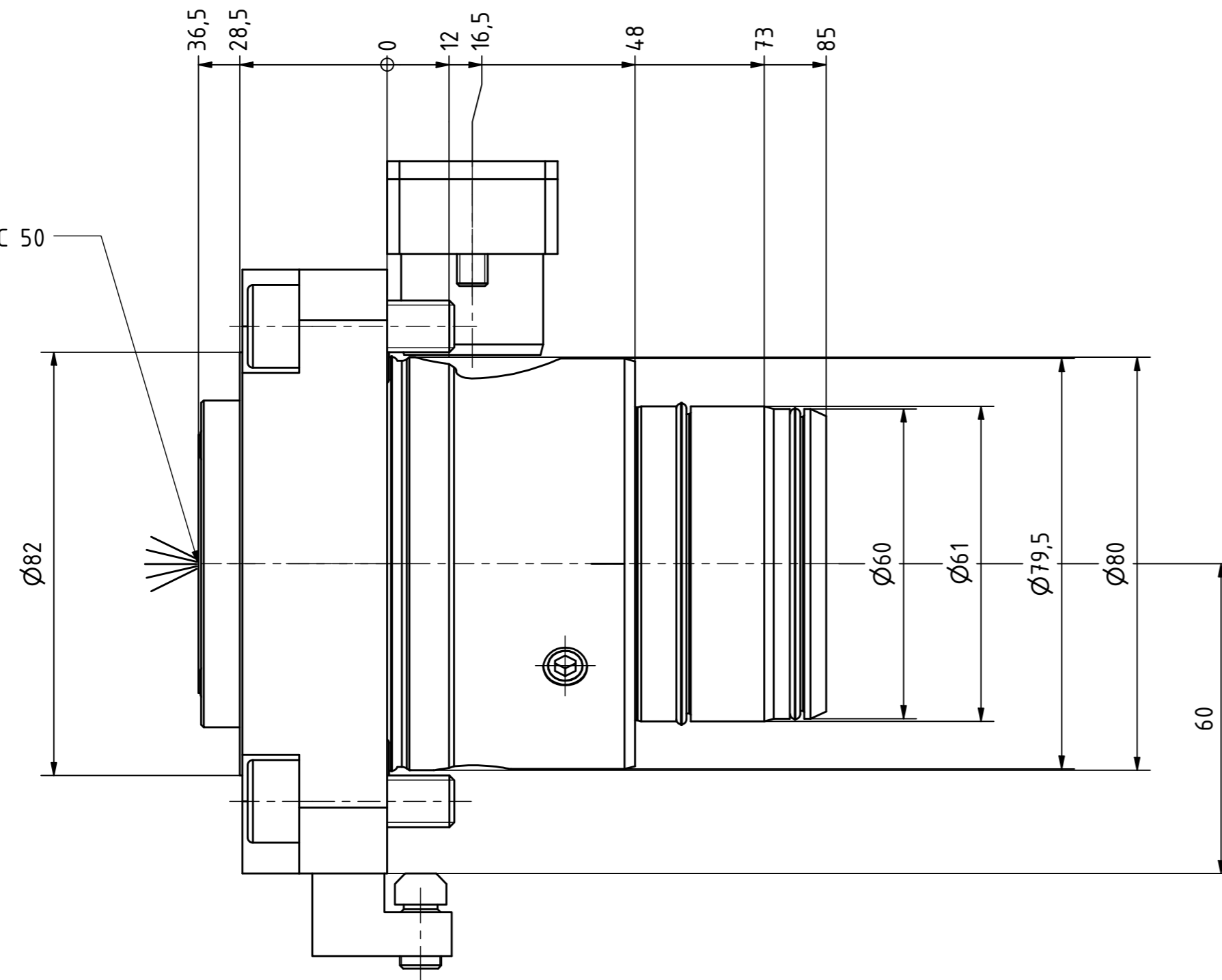

Copyright **EWS Tool Technologies**
 Weitergabe und Vervielfältigung dieser Unterlage,
 Verwertung und Mitteilung ihres Inhalts nicht
 gestattet, soweit nicht ausdrücklich zugestanden.
 Zuwiderhandlungen verpflichten zu Schadenersatz.

<p>Bemerkung - Note</p> <p>MA = 70 Nm max. 80 bar</p>	<p>Technische Daten - technical data</p> <p>Weight = 5.811 [kg]</p>	<p>Benennung - Title</p> <p>Werkzeugaufnahme <i>Tool adaptor</i></p>	<p>EWS Tool Technologies <small>EWS Weigle GmbH & Co. KG Maybachstr. 1 D-73066 Uhingen www.ews-tools.de</small></p>	<p>Technische Änderungen vorbehalten! Subject to technical modifications!</p> <p>IDENT: DEWS239064</p>	<p>REV: -/G</p> <p>MNR.</p> <p>205182</p>	<p>QR</p>
---	---	---	--	---	---	------------------