

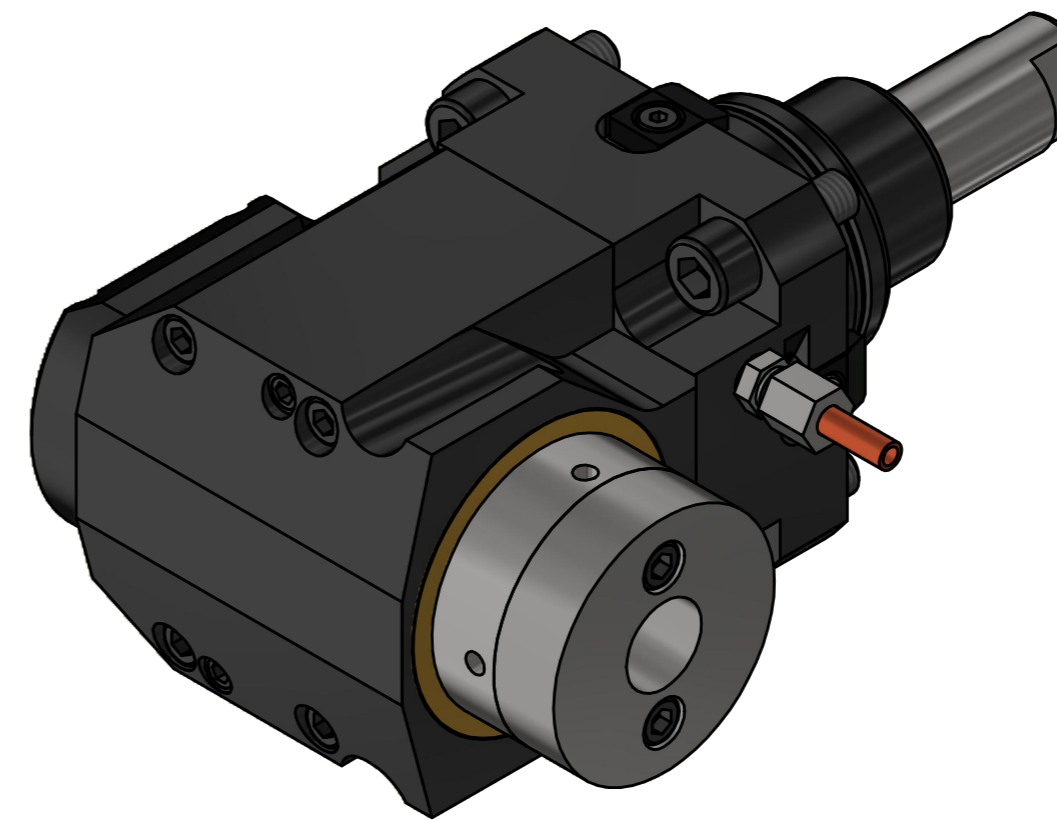



Hydrodehnfutter / hydraulic chuck NBC-20/25-46

Hülsen / collets 28.20xxHYDxx

XX (Ø) 3 4 5 6 7 8 9 10 12 14 16  
 1/8 3/16 1/4 5/16 3/8 7/16 1/2 9/16 5/8



Copyright **EWS Tool Technologies**  
 Weitergabe und Vervielfältigung dieser Unterlage,  
 Verwertung und Mitteilung ihres Inhalts nicht  
 gestattet, soweit nicht ausdrücklich zugestanden.  
 Zuwiderhandlungen verpflichten zu Schadenersatz.

Bemerkung - Note	Technische Daten - technical data Weight = 6.702 [kg] Torque max. (M1/M2) = 50 / 50 [Nm] Speed max. (n1/n2) = 6000 / 6000 [1/min] Gear ratio (i)=n1:n2 = 1:1	Benennung - Title <b>Radial Bohr und Fräskopf</b> <b>Radial drilling and milling head</b>	 <b>EWS</b> Weigle GmbH & Co. KG Maybachstr. 1 D-73066 Uhlingen www.ews-tool.de	Technische Änderungen vorbehalten! Subject to technical modifications! IDENT: DEWS051271 Nr. - No. <b>60.5520HYDVL4</b>	 MNR REV: -/C <b>208970</b>	
------------------	--	---	---	--	--	---