

Spannzange / collet ER25 DIN6499
 Spannbereich / clamping range: 1,0 - 16,0

Gewindebohrzange / tapping collet
 ET-1-25 M3-M12

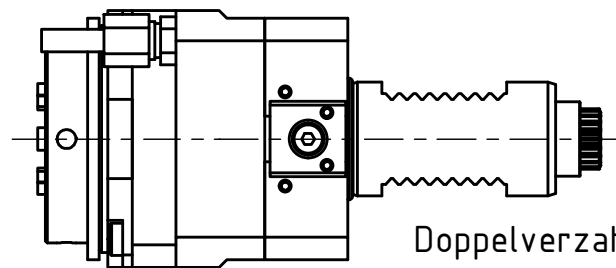

Doppelverzahnung Lizenz Traub
 double tooth system licence Traub

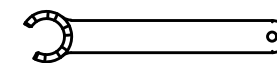
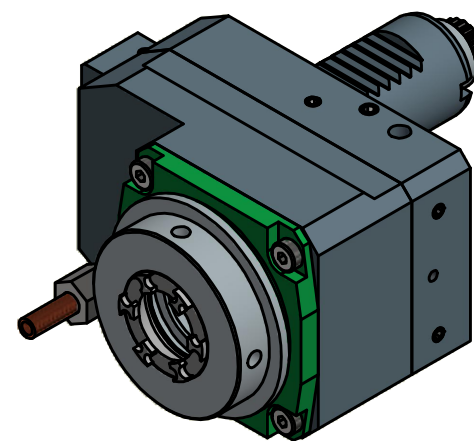

Spannzangenschlüssel für
 innenliegende Mutter
 Clamping wrench for
 internal collet
 225AX

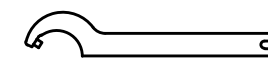

Hakenschlüssel
 mit Zapfen
 Hook wrench
 with fixed pin
 DIN1810 B 52x55

Copyright **EWS Tool Technologies**
 Weitergabe und Vervielfältigung dieser Unterlage,
 Verwertung und Mitteilung ihres Inhalts nicht
 gestattet, soweit nicht ausdrücklich zugestanden.
 Zuwiderhandlungen verpflichten zu Schadenersatz.

Bemerkung - Note

Technische Daten - technical data

Weight = 3.116 [kg]
 Torque max. (M1/M2) = 24 / 12 [Nm]
 Speed max. (n1/n2) = 6000 / 12000 [1/min]
 Gear ratio (i)=n1:n2 = 1:2

Benennung - Title

Axial Bohr u. Fräskopf achsversetzt
Ax. drill. and mill. head offset



EWS Weigele GmbH & Co. KG
 Maybachstr. 1
 D-73066 UHINGEN
 www.ews-tools.de

Technische Änderungen vorbehalten!
 Subject to technical modifications!

IDENT: DEWS061849



REV: -/B

Nr. - No.

50.3025CTXRL11M#01

MNR.

204249

