

W-Verzahnung Lizenz Index-Werke
W-tooth system licence Index-Corporation

Spannzange / *collet* ER32 DIN6499
 Spannbereich / *clamping range*: 2,0 - 20,0

Gewindebohrzange / *tapping collet*
 ET-1-32 M5-M12

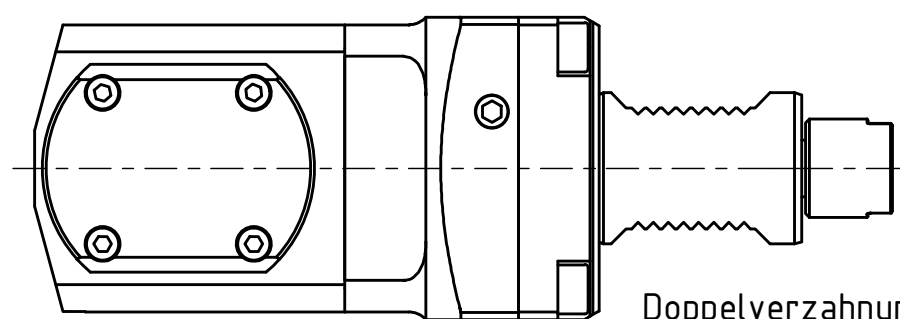
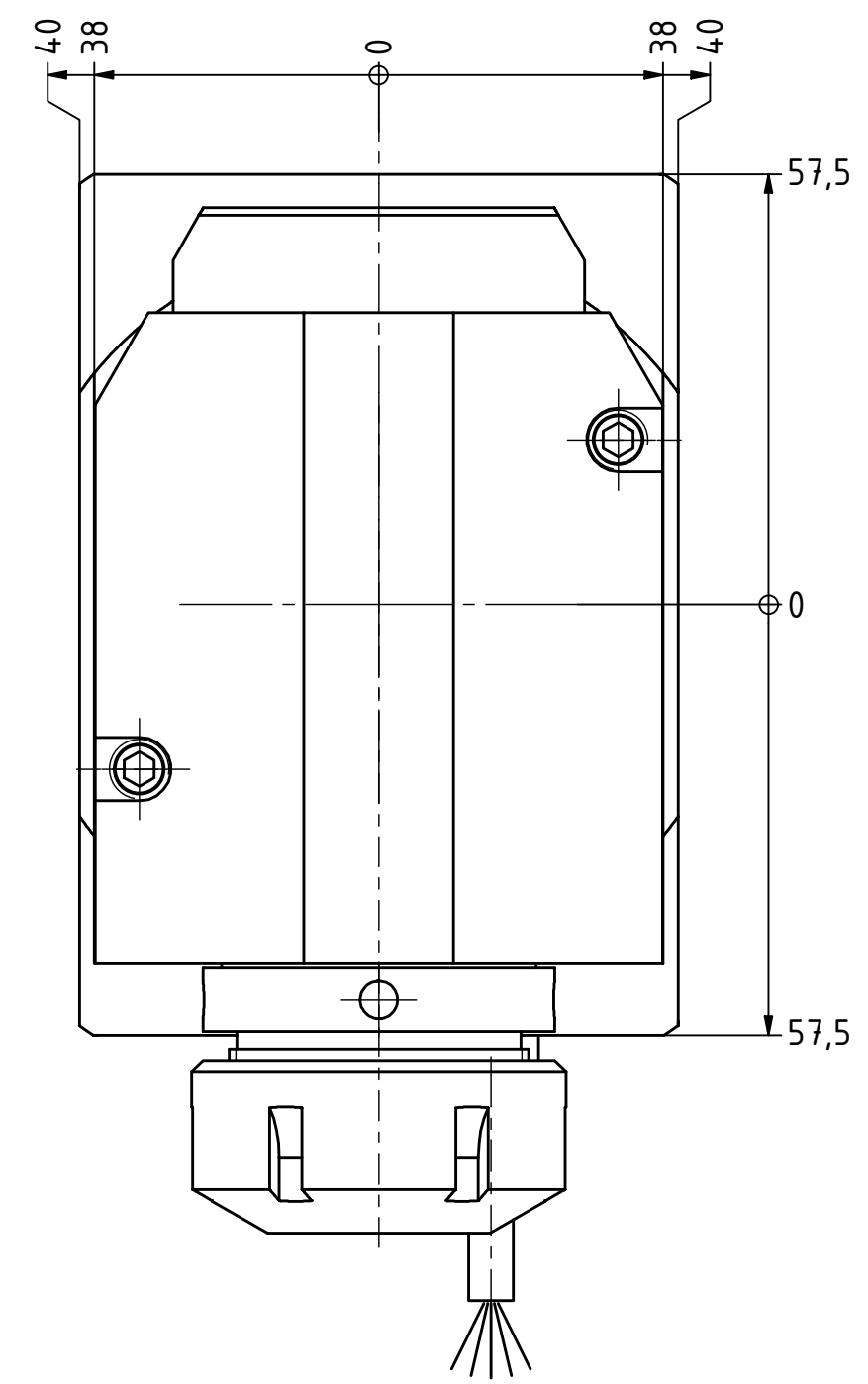
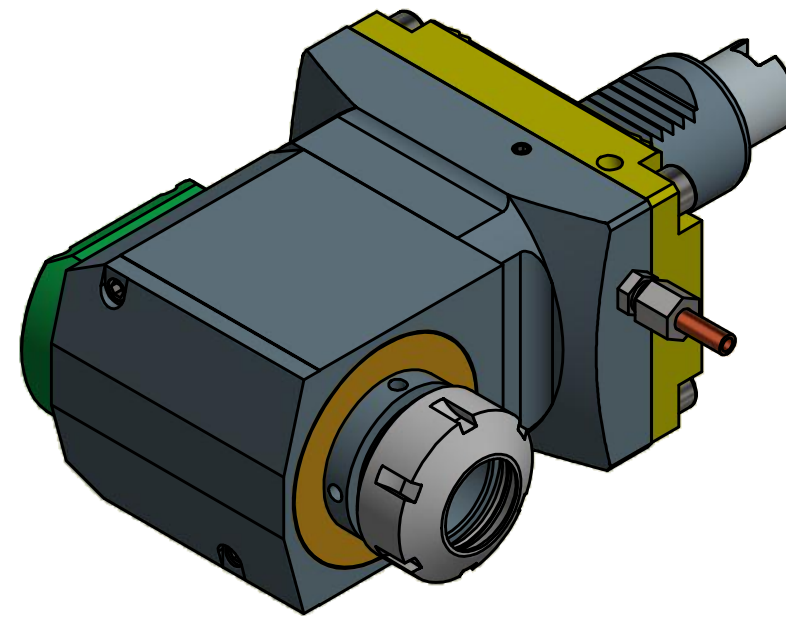
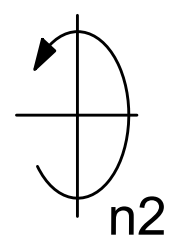

Doppelverzahnung Lizenz Traub
double tooth system licence Traub





Spannzangenschlüssel
Clamping wrench
 232



Hakenschlüssel
 mit Zapfen
*Hook wrench
 with fixed pin*
 DIN1810 B 4,5x50

Copyright **EWS Tool Technologies**
 Weitergabe und Vervielfältigung dieser Unterlage,
 Verwertung und Mitteilung ihres Inhalts nicht
 gestattet, soweit nicht ausdrücklich zugestanden.
 Zuwiderhandlungen verpflichten zu Schadenersatz.

Bemerkung - <i>Note</i>	Technische Daten - <i>technical data</i> Weight = 8,095 [kg] Torque max. (M1/M2) = 50 / 50 [Nm] Speed max. (n1/n2) = 6000 / 6000 [1/min] Gear ratio (i)=n1:n2 = 1:1	Benennung - <i>Title</i> Radial Bohr und Fräskopf <i>Radial drilling and milling head</i>	 EWS Weigle GmbH & Co. KG Maybachstr. 1 D-73066 Uhingen www.ews-tools.de Technische Änderungen vorbehalten! <i>Subject to technical modifications!</i> IDENT: DEWS064985 Nr. - <i>No.</i> 60.4032G250RLWX110 MNR. 208318 REV: -/A	
-------------------------	---	--	---	---