

Hydrodehnfutter / hydraulic chuck NBC-20/25-46

Hülsen / collets 28.20xxHYDSP

XX (Ø)	3	4	5	6	7	8	9	10	12	14	16
	1/8	3/16	1/4	5/16	3/8	7/16	1/2	9/16	5/8		

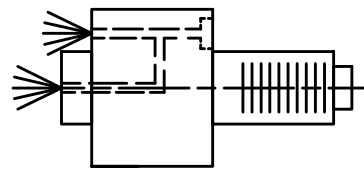

Innen- und Aussenkühlung / Inside and outside coolant supply
 Kühlmittelfiltrierung <math>< 50\mu</math> / coolant filtration <math>< 50\mu</math>

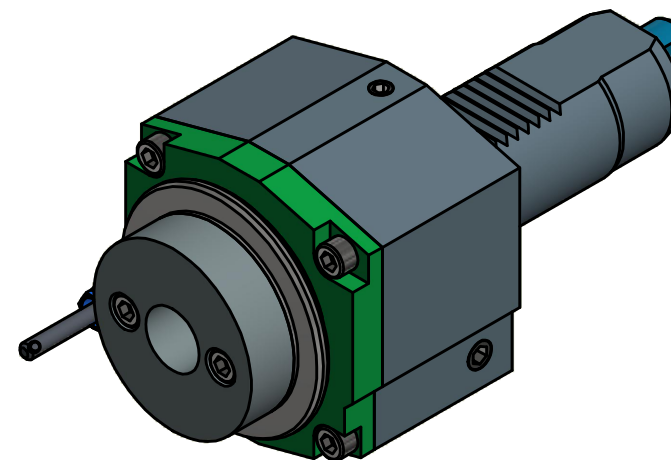

Copyright **EWS Tool Technologies**
 Weitergabe und Vervielfältigung dieser Unterlage,
 Verwertung und Mitteilung ihres Inhalts nicht
 gestattet, soweit nicht ausdrücklich zugestanden.
 Zuwiderhandlungen verpflichten zu Schadenersatz.

Bemerkung - Note
 Für Trockenlauf geeignet!
 Use without coolant fluid allowed!

Technische Daten - technical data
 Weight = 4.050 [kg]
 Torque max. (M1/M2) = 50 / 50 [Nm]
 Speed max. (n1/n2) = 6000 / 6000 [1/min]
 Gear ratio (i)=n1:n2 = 1:1
 Pressure (pmax) = 70 [bar]

Benennung - Title
Axial Bohr und Fräskopf
Axial drilling and milling head



Nr. - No.
40.4020HYDVL3IKC

Technische Änderungen vorbehalten!
 Subject to technical modifications!
 IDENT: DEWS128678

REV: -/E
 MNR.
199004

