

Spannzange / collet ER32 DIN6499  
Spannbereich / clamping range: 2,0 - 20,0

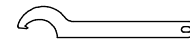

Hakenschlüssel  
mit Nase  
Hook wrench with  
nose end  
DIN1810 A 58x62

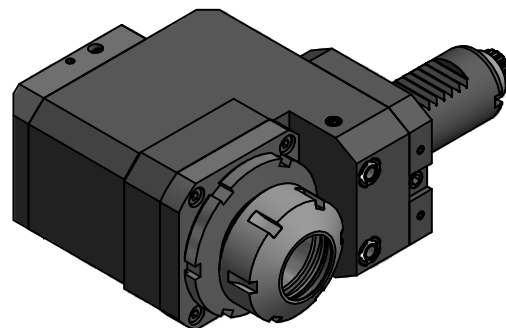

Spannzangenschlüssel  
Clamping wrench  
232

Copyright **EWS Tool Technologies**  
Weitergabe und Vervielfältigung dieser Unterlage,  
Verwertung und Mitteilung ihres Inhalts nicht  
gestattet, soweit nicht ausdrücklich zugestanden.  
Zuwiderhandlungen verpflichten zu Schadenersatz.

Innen- und Aussenkuehlung / Inside and outside coolant supply  
Kein Trockenlauf / No dry run  
Kuehmittelfiltrierung-50µ / coolant filtration-50µ

Bemerkung - Note  
Nicht ohne Kuehlmittel betreiben!  
Not for use without coolant-fluid!  
mit Kegelrollenlager  
with taper roller bearing(s)

Technische Daten - technical data  
Weight = 4.710 [kg]  
Torque max. (M1/M2) = 20 / 60 [Nm]  
Speed max. (n1/n2) = 6000 / 2000 [1/min]  
Gear ratio (i)=n1:n2 = 3:1  
Pressure (pmax) = 70 [bar]

Benennung - Title



Nr. - No.  
**80.3032KRCTXRIK13**

Technische Aenderungen vorbehalten!  
Subject to technical modifications!  
IDENT: DEWS021991

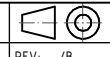

REV: -/B

MNR.  
**200133**

